

KeDrive D3

Drive System

Order Catalogue



Supply units, axis controllers, additional modules,
accessories, software, sector-specific components,
machine safety solutions, servomotors

KEBA[®]
Automation by innovation.

KeDrive D3-DP supply units (passive)



KeDrive D3-DP supply units (active)

KeDrive D3-DL
charging moduleKeDrive D3-DP 310
supply module

KeDrive D3-DA axis controller

KeDrive D3-EM
energy managerKeDrive D3-ES
energy storage

KeDrive D3 Drive System

Order Catalogue

ID no.: 1404.205B.0-01 • Date: 11/2022

Subject to technical change without notice.

The content of our catalogue was compiled with the greatest care and attention, and based on the latest information available to us.

We should nevertheless point out that this document cannot always be updated simultaneously with the ongoing technical development of our products.

Information and specifications may be subject to change at any time. For information about the latest version please visit www.keba.com.

Additional modules



Accessories



KeStudio DriveManager



Expansion module, CNC laser machining, safe encoder box



Machine safety solution, FSoE master, FSM modules, SafetyManager



Servomotors



Product overview

Chapter 1 System description	1
Chapter 2 Passive supply units	2
Chapter 3 Active supply unit	3
Chapter 4 Axis controllers	4
Chapter 5 Controlled Energy storage system	5
Chapter 6 additional modules	6
Chapter 7 Accessories	7
Chapter 8 Engineering software with KeStudio	8
Chapter 9 Sector-specific components	9
Chapter 10 Machine safety components	10
Chapter 11 Servomotors	11

Table of contents

1	KeDrive D3 system description.....	11
1.1	System components and guidelines	11
1.2	Typical system layout and configuration example	13
1.4.1	Components used for the configuration example	14
1.3	Services	15
1.4	Ambient conditions for the KeDrive D3 devices.....	17
2	Passive supply units.....	19
2.1	System overview.....	19
2.2	KeDrive D3-DP 30x supply units	20
2.2.1	Overview of the connections, KeDrive D3-DP 300 supply unit (BG1).....	21
2.2.2	Overview of the connections, KeDrive D3-DP 300 supply unit (BG2).....	22
2.2.3	Overview of the connections, D3-DP 301/A 37 kW *) supply unit (BG2)	23
2.2.4	Overview of the connections, KeDrive D3-DP 301 supply unit (BG3).....	24
2.2.5	Overview of the connections, KeDrive D3-DP 301 supply unit (BG4).....	25
2.2.6	Order code, KeDrive D3-DP 30x supply unit	26
2.2.7	Technical data, KeDrive D3-DP 30x supply unit.....	27
2.2.8	Installation and dimensions, KeDrive D3-DP 30x supply unit.....	35
2.2.9	Connector sets, KeDrive D3-DP 30x supply units	39
3	Active supply unit.....	43
3.1	System overview	43
3	KeDrive D3-DA supply unit (active)	44
3.1.1	Overview of the connections, KeDrive D3-DL 300 charging module	44
3.1.2	Overview of the connections, KeDrive D3-DP 310 supply modules	45
3.1.3	Order code, KeDrive D3-DL 300 charging module	46
3.1.4	Order code, KeDrive D3-DP 310 supply modules	46
3.1.5	Technical data, KeDrive D3-DL 300 charging module	47
3.1.6	Technical data, KeDrive D3-DP 310 supply modules.....	48
3.1.7	Dimensions, charging module and supply module (heat sink)	49
3.1.8	Dimensions, supply module (liquid cooling)	50
3.1	Connector sets	52
4	Axis controllers	55
4.1	System overview.....	55
4.2	D3-DA 3xx - axis controllers	56
4.2.1	Overview of the connections, D3-DA 3xx (BG1).....	57
4.2.2	Overview of the connections, D3-DA 3xx (BG2)	58

4.2.3	Overview of the connections, D3-DA 3xx (BG3)	59
4.2.4	Overview of the connections, D3-DA 3xx axis controller (BG4).....	60
4.2.5	Order code, D3-DA 3xx axis controller -	61
4.2.6	Power and function overview, D3-DA 3xx axis controller.....	63
4.2.7	Installation and dimensions, D3-DA 3xx axis controller	69
4.2.8	Connector sets, D3-DA 3xx axis controller	75
5	Controlled Energy storage system KeDrive D3	77
5.1	System overview	77
5.1.1	Introduction	78
5.1.2	Overview of the connections, KeDrive D3-EM energy manager	79
5.1.3	Overview of the connections, KeDrive D3-ES energy storage	80
5.1.4	Order code, KeDrive D3-EM energy manager	81
5.1.5	Order code, KeDrive D3-ES energy storage	81
5.1.6	Technical data, KeDrive D3-EM energy manager	82
5.1.7	Technical data, KeDrive D3-ES energy storage	83
5.1.8	Dimensions, energy manager and energy storage (heat sink).....	84
5.1.9	Dimensions, energy manager (liquid cooling).....	86
5.1.10	Connector sets.....	87
5.1.11	Accessories, choke module KeDrive D3-EL	89
6	KeDrive D3 additional modules	91
6.1	KeDrive D3 system overview.....	91
6.2	D3-DE 300 expansion module.....	92
6.2.1	Overview of the connections, D3-DE 300 expansion module.....	92
6.2.2	Order code, D3-DE 300 expansion module.....	93
6.2.3	Technical data, KeDrive D3 expansion module.....	94
6.2.4	Installation and dimensions, D3-DE 300 expansion module	94
6.2.5	Connector sets, D3-DE 300 expansion module	95
6.2.6	Connector set, DC link connection connectors	96
6.3	D3-DC 300 capacitance module	97
6.3.1	Overview of the connections	97
6.3.2	Order code	98
6.3.3	Technical data, KeDrive D3 capacitance module D3-DC 300.....	98
6.3.4	Installation and dimensions, D3-DC 300 capacitance module	99
6.3.5	Connector set for D3-DC 300	100
6.4	Connection module KeDrive D3-XV	101
6.4.1	Overview of the connections	101
6.4.2	Technical data, KeDrive D3-XV.....	101
6.4.3	Dimensions, KeDrive D3-XV	101

7	KeDrive D3 accessories	103
7.1	KeDrive D3 - accessories (additional components).....	103
7.2	Document set.....	104
7.3	Accessories for axis controllers.....	105
7.3.1	Accessory set for axis controllers BG1 + BG2.....	105
7.3.2	Ethernet cable for axis controllers BG3	105
7.3.3	Ethernet cable for axis controllers BG4	106
7.3.4	Ethernet cable (standard)	106
7.3.5	Ethernet cable (without cross-communication).....	106
7.4	Mains chokes	107
7.5	Braking resistors.....	109
7.6	Mains filters	116
7.6.1	Mains filter dimensioning	118
7.6.2	Power-dependent technical data, three-phase mains filters	121
7.6.3	Dimensions, three-phase mains filters	121
8	Engineering software with KeStudio	125
8.1	Engineering software Kemro X.....	126
8.2	PC user software - KeStudio DriveManager.....	127
9	Sector-specific components.....	129
9.1	Overview	129
9.2	KeDrive D3-IM 300 for laser machining.....	130
9.2.1	Overview of the connections	130
9.2.2	Order code.....	131
9.2.3	Installation and dimensions, KeDrive D3-IM 300 expansion module	131
9.2.4	Connection example:.....	132
9.3	KeDrive D3-SMM safe encoder box.....	133
9.3.1	Overview of the connections	133
9.3.2	Order code:	133
9.3.3	Technical data	134
9.3.4	Accessories for KeDrive D3-SMM encoder box	136

10	Machine safety components	139	
10.1	System overview.....	139	1
10.2	KeDrive D3-DA SDC (FSoE slave)	140	
10.3	FSM-1 module (FSoE master)	141	
10.3.1	Technical data, FSM-1	142	2
10.4	FSM-2 module (FSoE master)	143	
10.4.1	Technical data, FSM-2.....	144	
10.5	SafetyManager	145	3
11	Servomotors	147	
11.1	Overview	147	
11.1.1	Servomotors order catalogues.....	149	4
11.2	System cables	150	

1

2

3

4

5

6

7

8

9

10

11

1 KeDrive D3 System description

Safe, energy-efficient multi-axis drive system

KeDrive D3 is one of the most compact multi-axis-drive systems with integrated safety technology. As a modular all-in-one system, it can be configured easily and quickly using a modern tool suite. The latest technology, greatest cost effectiveness and maximum availability are typical features of this innovative drive solution

Features:

- Compact, continuous form factor
- Modular, scalable system layout
- 1, 2 and 3-axis drive modules from 1.5 A – 250 A
- Up to 300% overload capacity
- Active and passive supply units from 10 kW – 140 kW
- Integrated safety technology as per PLe, cat 4 or SIL3
- Energy storage and expansion modules
- Servomotors for a very wide range of load cases



1.1 System components and guidelines

Device	D3-DP 300 supply unit BG1+2	D3-DP 301 supply unit BG3+4	D3-DC 300 capacitance module	D3-DE 300 expansion module	D3-XV connec- tion module
--------	--------------------------------	--------------------------------	------------------------------------	-------------------------------	------------------------------

Fig.



For details see	Chapter 2 KeDrive D3 - passive supply units		Chapter 6: KeDrive D3 - additional modules		
Operation manual	1404.201B.x	1804.201B.x	1804.203B.x	1804.202B.x	1804.211B.x

Device	KeDrive D3-DL 300 charging module	KeDrive D3-DP 310 supply module	KeDrive D3-EM energy manager	KeDrive D3-ES energy storage
--------	-----------------------------------	---------------------------------	------------------------------	------------------------------

Fig.



For details see	Chapter 3: KeDrive D3 active supply unit	Chapter 5: Controlled energy storage system	
Operation manual	1404.201B.x	1804.201B.x	1804.209B.x

Device	KeDrive D3-DA 3xx axis controller BG1+2	KeDrive D3-DA 3xx axis controller BG3+4	KeStudio DriveManager software
--------	---	---	--------------------------------

Fig.



For details see	Chapter 4 KeDrive D3 - axis controllers		Chapter 8 Engineering software
Operation manual	1404.200B.x	1804.200B.x	

Device	EMC mains filter	Mains choke	Braking resistors	Accessories (EMC, cables)	Servomotors
--------	------------------	-------------	-------------------	---------------------------	-------------

Fig.



For details see	Chapter 7 KeDrive D3 - accessories			Chapter 11 Servomotors
-----------------	------------------------------------	--	--	------------------------

1.2 Typical system layout and configuration example

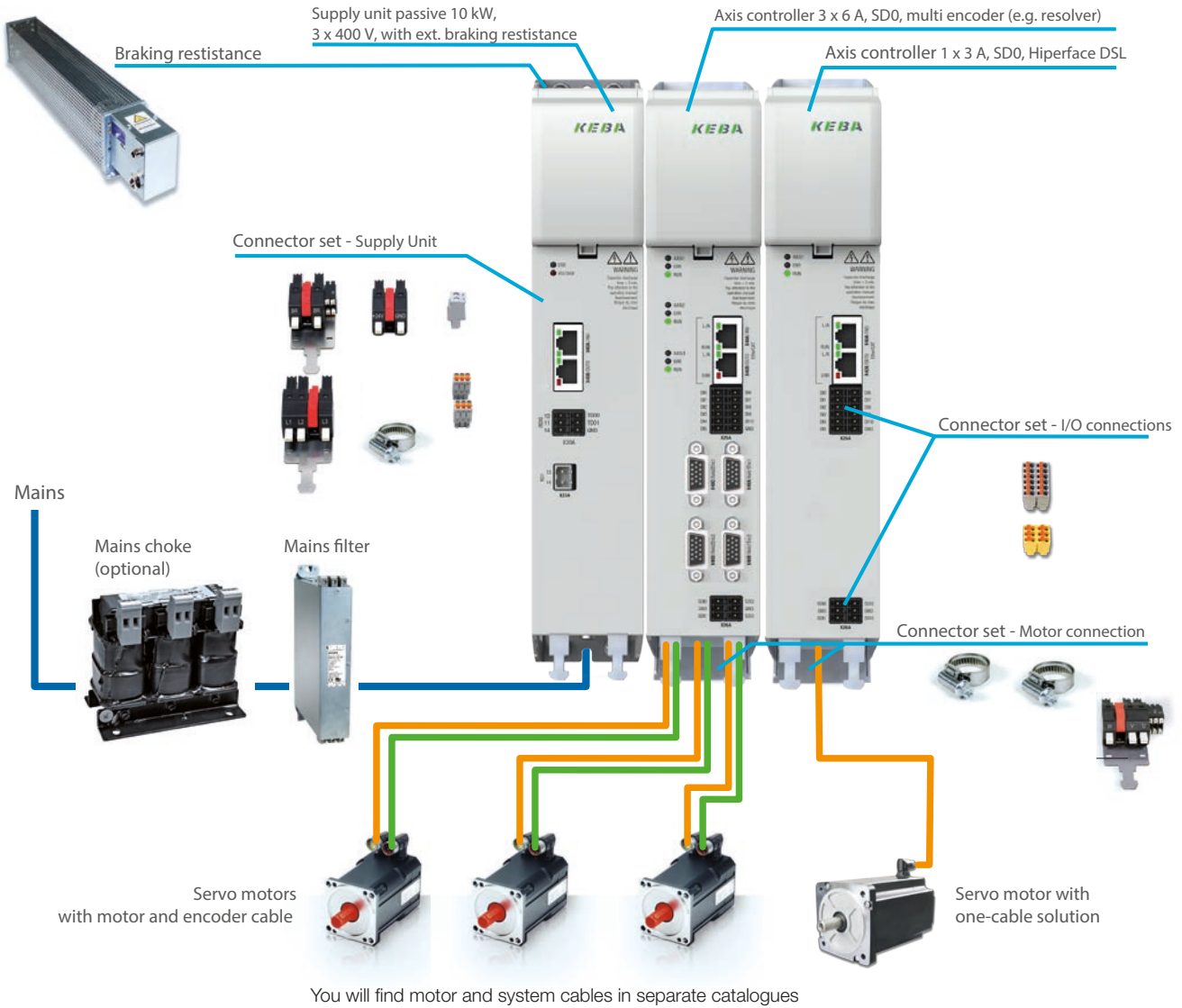

1.4.1 Components used for the configuration example

Designation	Order code	Number of pieces	Usage	See chapter
Supply unit (passive) 10 kW: <ul style="list-style-type: none"> • Mains supply 3 x 400 V • External braking resistor • No integrated 24 V switched-mode power supply 	D3-DP 300/A-1000-0101-0000	1	For the generation of the DC supply voltage for the axis controllers	Chapter 2.2.1
Connector set, supply unit	D3-XT 220/B	1	Power-dependent connector set for the supply unit D3-DP300/x-10xx-xxxx-xxxx	Chapter 2.2.9
Axis controller, three axes, 6 A each <ul style="list-style-type: none"> • Multi-encoder interface, e.g. resolver • Safety technology "SD0": STO & SBC • EtherCAT field bus 	D3-DA 330/A-0611-0201-0000	1	For servomotor drive with encoders suitable for the multi-encoder interface (e.g. resolvers). (Type is dependent on the application)	Chapter 4.2.1
Axis controller, one axis, 3 A <ul style="list-style-type: none"> • Hiperface DSL interface • Safety technology "SD0": STO & SBC • EtherCAT field bus 	D3-DA 310/A-0321-0201-0000	1	For servomotor drive with Hiperface DSL encoders. (Type is dependent on the application)	
Connector set, I/O connections, axis controller	D3-XT 230/A	2	I/O connector set. Required for each axis controller	Chapter 4.2.8
Connector set, motor connection, axis controller	D3-XT 231/A	4	Power-dependent connector set for the connection of one axis controller, 1 set required per motor.	
Mains choke: $u_k = 2\%$	LR34.20-UR	1 (optional)	Optional for the reduction of the peak mains currents and distortion in the mains (THD). Also contributes to increasing the service life.	Chapter 7.4
Braking resistor (BR): 39 Ω , $P_D = 150$ W, $P_{peak} = 3.3$ kW	BR-039.02.540-UR	1	Required for each passive supply unit D3-DP30x. Not required for devices with int. braking resistor. (Type is dependent on the application)	Chapter 7.5
Mains filter: 25 A, 120 m	EMC25.120-UR	1	Required for each KeDrive D3 drive system to comply with the applicable EMC standards. (Type is dependent on the application)	Chapter 7.6
Software	KeStudio DriveManager	1	Min. 1 piece required per customer to configure the parameters for the axis controllers	Chapter 8.2
Motors, motor and encoder cables			See separate catalogues for motors and system cables	Chapter 11

1.3 Services

The screenshot displays the KEBA website's navigation and service sections. At the top, there is a navigation bar with links for Business Areas, About, Career, News, and Contact, along with a search icon. The KEBA logo and tagline 'Automation by innovation.' are positioned on the right. Below this is a green header bar with three main categories: Industrial Automation, Handover Automation, and Energy Automation. A grid of seven service tiles follows, each with an image and a title: Mechanical Engineering, Machine tools, Sheet metal processing, Plastics, Robotics, Turbo systems, and Wind Energy. A 'Current news' section is also visible, featuring two articles with photos and dates.

Business Areas | About | Career | News | Contact |

KEBA
Automation by innovation.

Industrial Automation | Handover Automation | Energy Automation

Mechanical Engineering » | Machine tools » | Sheet metal processing » | Plastics »

Robotics » | Turbo systems » | Wind Energy »

Our solution for your machine

Mechanical engineering | Machine tools | Plastics | Robotics | Wind Energy | Turbo systems | Sheet metal processing

Your requirements make us grow

The challenge of growth today lies primarily in the speed with which we master it. KEBA offers technologies for mechanical engineering that enable global networking with cloud-based data management and intelligent IT integration. Both hardware and software are optimized for machine automation and robotics.

[Read more](#)

Current news

Gerhard Luitfensteiner EY Entrepreneur Of The Year 2022
18.10.2022
On October 14, this year's EY Entrepreneur Of The Year Award was presented in Austria. In the category "Sustainability & GreenTech" Gerhard Luitfensteiner, CEO of KEBA Group AG was awarded.
[Read more](#)

How a logistics solution provider ensures speed and flexibility.
14.10.2022
The logistics industry is facing major challenges, especially due to the boom in e-commerce. "More speed, precision, compactness and flexibility" also applies to TQW Robotics and its business partners - such as KEBA. Together, they have already been able to successfully implement several projects to optimize the logistics process and thus solve essential pain points in intralogistics.
[Read more](#)

KEBA Industrial Automation Germany GmbH provides comprehensive information via the Internet. Whether you are looking for more detailed technical information about our products or about project planning and design, or want to contact our nearest representative - just visit our website: **www.keba.com**.

Or call us on +49 6441 966-0 to obtain detailed information material on our broad range of services, available in printed form as a convenient reference source.

Design-in

Professional project management that keeps you to deadlines and budgets is an important element of our joint success. The sooner you get to market with your new solution the better. That is why we can support you in:

- Analysing requirements
- Project planning and drive design
- Preparing the functional specification
- Total cost analysis
- Project management

Logistics

To make ordering a routine exercise and reduce or even eliminate unnecessary formalities, the entire process is coordinated, from planning through ordering to spare parts supplies.

Software update service

As part of our product maintenance function we are continuously improving the quality of the drive system. Our software update service provides you with information about new releases and enhancements to the various firmware versions.

After-sales

You can call on our service and support wherever and whenever you need them. With our flexibility, fast response times, superior technical know-how and extensive user experience, we can offer a wide range of services, including:

- Remote support via support hotline.
- On-site service.
- Repair / service concept.

Helpline

Take advantage of the KEBA ticket system. Obtain technical information and solutions to problems direct from our competent support staff. We will process your enquiry without delay and give you feedback on your issue.

To contact the Helpline for drive technology:

Hotline: +49 6441 966 180
 E-mail: helpline@keba.de

To contact the Helpline for control technology:

Hotline: +43 732 7090 23222
 E-mail: support-a@keba.com

You can reach us
 Monday to Thursday 08:00 to 17:00 and
 Friday 08:00 to 16:00.

Downloads

You will find the latest comprehensive information about our products on our website:

www.keba.com in [Documentation and Downloads](#)

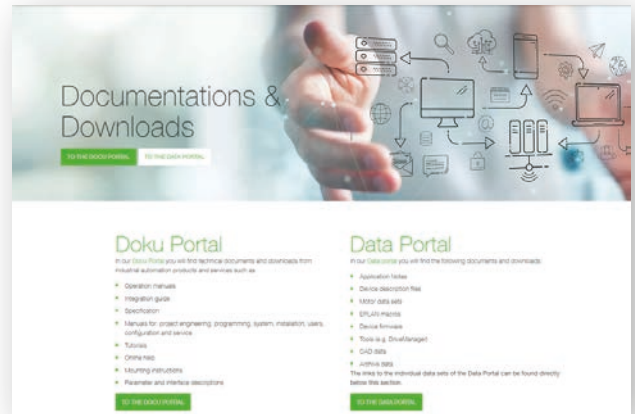
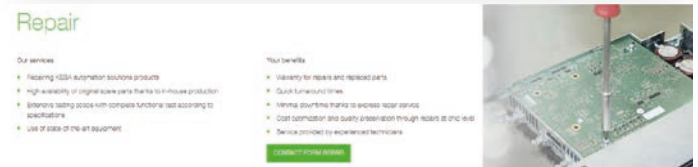
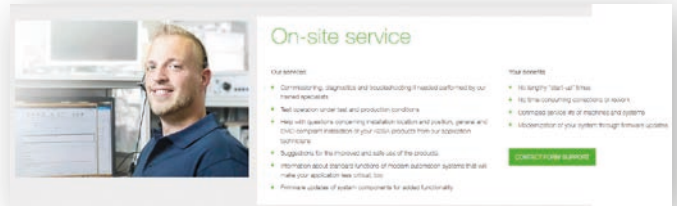
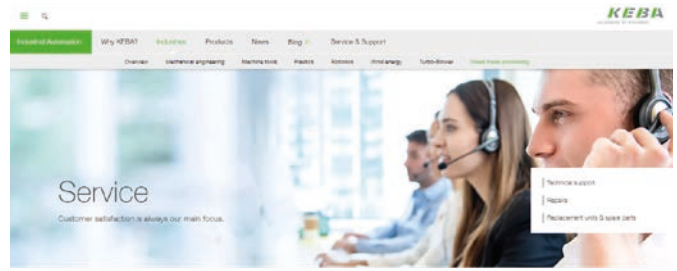

1.4 Ambient conditions for the KeDrive D3 devices

Ambient conditions	KeDrive D3 devices *)
Degree of protection, device	IP20 except terminals (IP00)
Degree of protection, switch cabinet	IP4X, with safety function STO or SDC IP54 or better (as per EN ISO 13849-2)
Health and safety regulations	As per the local regulations (in Germany e.g. BGV V3)
Installation altitude	Up to 1000 m above MSL, higher with power reduction (1% per 100 m, max. 2000 m above MSL), overvoltage category III > 2000 m: overvoltage category II
Pollution degree	2 as per EN
Type of mounting	Built-in unit, only for vertical installation in a switch cabinet with min. degree of protection IP4x, while using safety function STO min. IP54
*) You will find specific conditions for the axis controller and supply unit in the related chapters.	KeDrive D3 axis controller: see chapter 1.4.1 on page 14 D3-DP 300 supply unit: see chapter 1.4.1 on page 14

Climatic conditions	KeDrive D3 devices	
During transport 1)	As per EN 61800-2, IEC 60721-3-2 class 2K3	
	Temperature	-25 °C to +70 °C
	Relative atmospheric humidity	95% at max. +40 °C
In storage 2)	As per EN 61800-2, IEC 60721-3-1 class 1K3 and 1K4	
	Temperature	-25 °C to +55 °C
	Relative atmospheric humidity	5% to 95%
In operation 3)	As per EN 61800-2, IEC 60721-3-3 class 3K3	
	Temperature	5 °C to +40 °C (4, 8, 16 kHz) up to 55 °C with power reduction
	Relative atmospheric humidity	5% to 85% without condensation

1) The absolute humidity is limited to max. 60 g/m³. This means that at 70 °C for example, the relative atmospheric humidity may only be max. 40%.

2) The absolute humidity is limited to max. 29 g/m³. So the maximum values for temperature and relative atmospheric humidity stipulated in the table must not occur simultaneously.

3) The absolute humidity is limited to max. 25 g/m³. So the maximum values for temperature and relative atmospheric humidity stipulated in the table must not occur simultaneously.

Mechanical conditions	KeDrive D3 devices		
Vibration limit in transit	As per EN 61800-2, IEC 60721-3-2 class 2M1		
	Frequency [Hz]	Amplitude [mm]	Acceleration [m/s ²]
	$2 \leq f < 9$	3.5	Not applicable
	$9 \leq f < 200$	Not applicable	10
Shock limit in transit	As per EN 61800-2, IEC 60721-3-2 class 2M1		
	Drop height of packed device max. 0.25 m		
Vibration limits for the system	As per EN 61800-2, IEC 60721-3-3 class 3M1		
	Frequency [Hz]	Amplitude [mm]	Acceleration [m/s ²]
	$2 \leq f < 9$	0.3	Not applicable
	$9 \leq f < 200$	Not applicable	1



NOTE:

KeDrive D3 devices are only allowed to be used in stationary applications and are not allowed to be subjected to any continuous vibration.

2 Passive supply units

2.1 System overview

Device	KeDrive D3-DP 30x supply unit BG1+2	KeDrive D3-DP 301 supply unit BG3+4
--------	--	--

Fig.



Type	D3-DP 300/x-10xx D3-DP 300/x-22xx D3-DP 301/A-37xx (not shown)	D3-DP 301/x-45xx D3-DP 301/x-90xx	D3-DP 301/x-A2xx
Operation manual	1404.201B.x		1804.201B.x



NOTE:

The latest operation manuals and other documents are available in German, English and other languages and can be downloaded from our homepage

<https://www.keba.com/de/industrial-automation/service-support/downloads/doku-data-portal>

2.2 KeDrive D3-DP 30x supply units

The power supply

The power for the multi-axis system comes from a central supply unit in steps from 10 kW to 140 kW. While for the supply units BG1+2 (10 - 22 kW) an integrated power supply unit (SMPS) optionally provides the 24 V/480 W auxiliary supply, for the supply units BG3+4 (45 - 140 kW) an external 24 V supply is required. This 24 V auxiliary supply can be provided by an existing 24 V power supply unit in the machine.

Axis controllers are arranged on the right of the supply unit on a rail system. The control modules D3-DU 3xx are mounted on the left. The connection of the axis controllers to the DC link supply and the 24 V DC auxiliary voltage is realised without wiring effort using the integrated busbar system. Only the 24 V DC auxiliary voltage is transmitted to the controller. Digital outputs indicate the actual status.

The supply unit supplies the energy for the axis controllers. Configuration, diagnostics and status information are realised via the first axis on the first axis controller in the drive group. A maximum of 9 modules are allowed to be connected and operated in the axis group (D3-DP, D3-DC, D3-DA, D3-DE...).

Safety technology

Test outputs provide OSSD output signals. The OSSD output signals are used for short-circuit and cross-circuit test on the wiring for the safe, digital inputs on the axis side.

Device protection/mains contactor

A relay output is provided with which it is possible to control an external mains contactor via the controller D3-DU 3xx integrated into the system.

2.2.1 Overview of the connections, KeDrive D3-DP 300 supply unit (BG1)

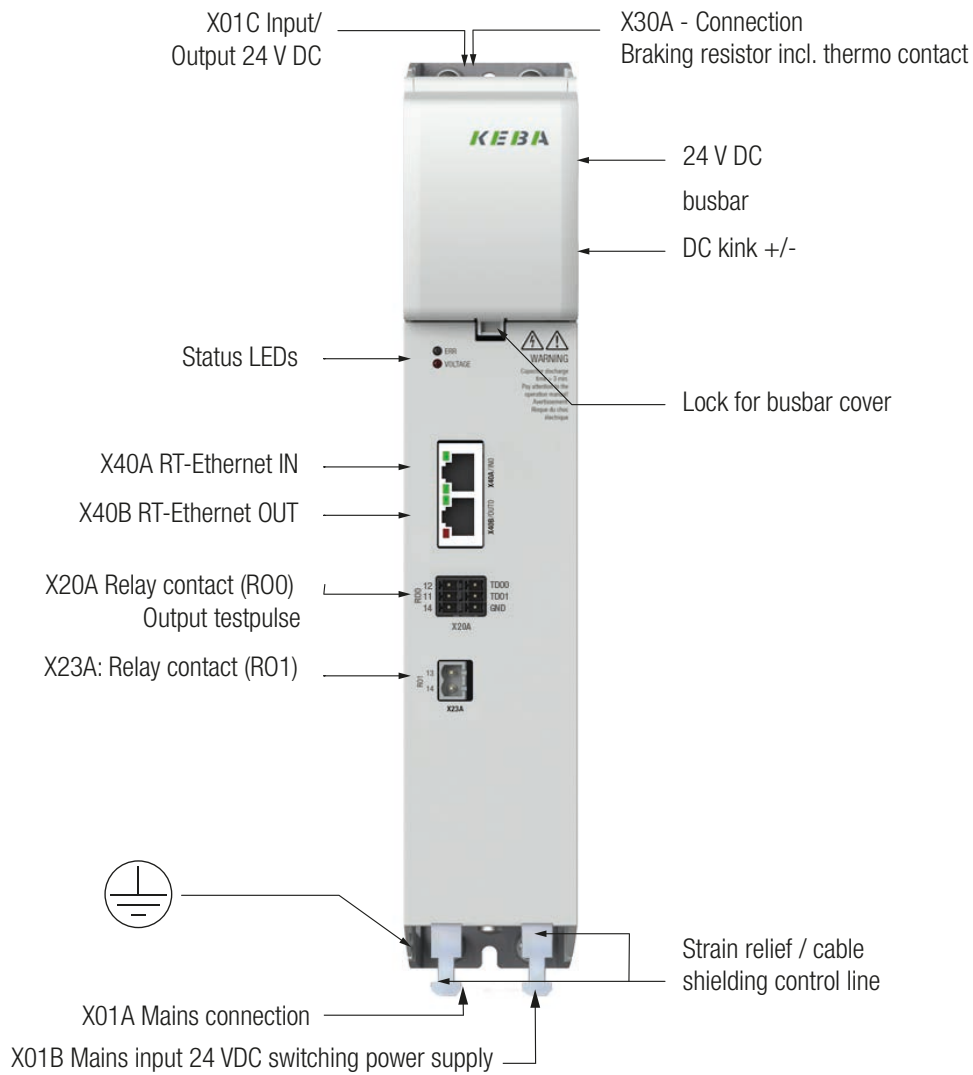

2



NOTE:

You will find descriptions and specifications for the above stated connections in the Operation Manual KeDrive D3-DP 30x Supply Unit BG1+2 (ID. no.: 1404.201B.x-xx).

Included in the scope of supply		For details see
Supply unit	D3-DP 300/x-10xx	Chapter 2.2.7
Busbar elements	For 24 V DC supply and DC link power supply (pre-assembled)	-
Documentation	Document set	Chapter 7.2
Optional (not included in the scope of supply)		
Connector set	For control and power connections	Chapter 2.2.9

2.2.2 Overview of the connections, KeDrive D3-DP 300 supply unit (BG2)

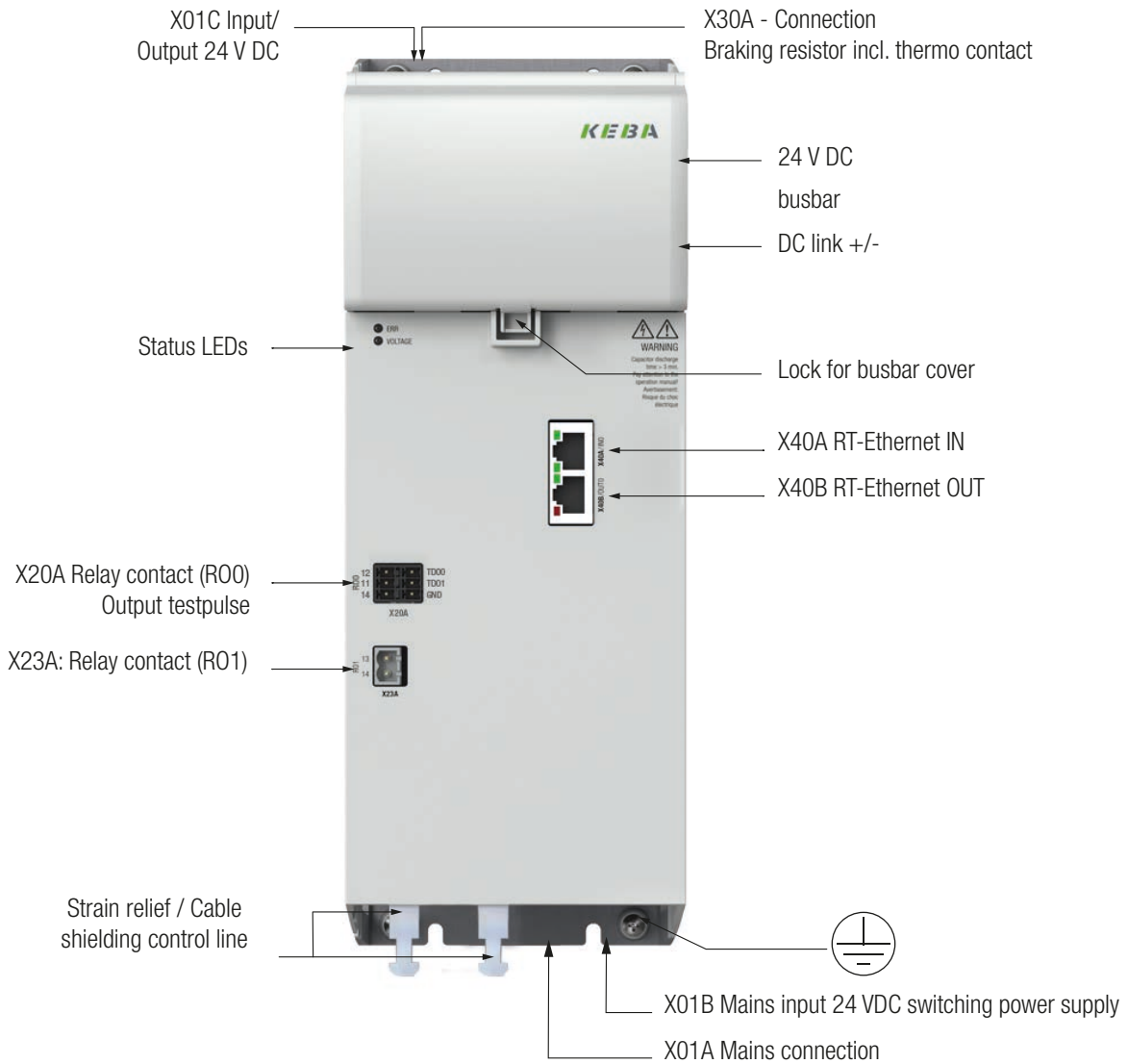

NOTE:

You will find descriptions and specifications for the above stated connections in the Operation Manual KeDrive D3-DP 30x Supply Unit BG1+2 (ID. no.: 1404.201B.x-xx).

Included in the scope of supply		For details see
Supply unit	D3-DP 300/x-22xx	Chapter 2.2.7
Busbar elements	For 24 V DC supply and DC link power supply	-
Documentation	Document set	Chapter 7.2
Optional (not included in the scope of supply)		
Connector set	For control and power connections	Chapter 2.2.9

2.2.3 Overview of the connections, D3-DP 301/A 37 kW *) supply unit (BG2)

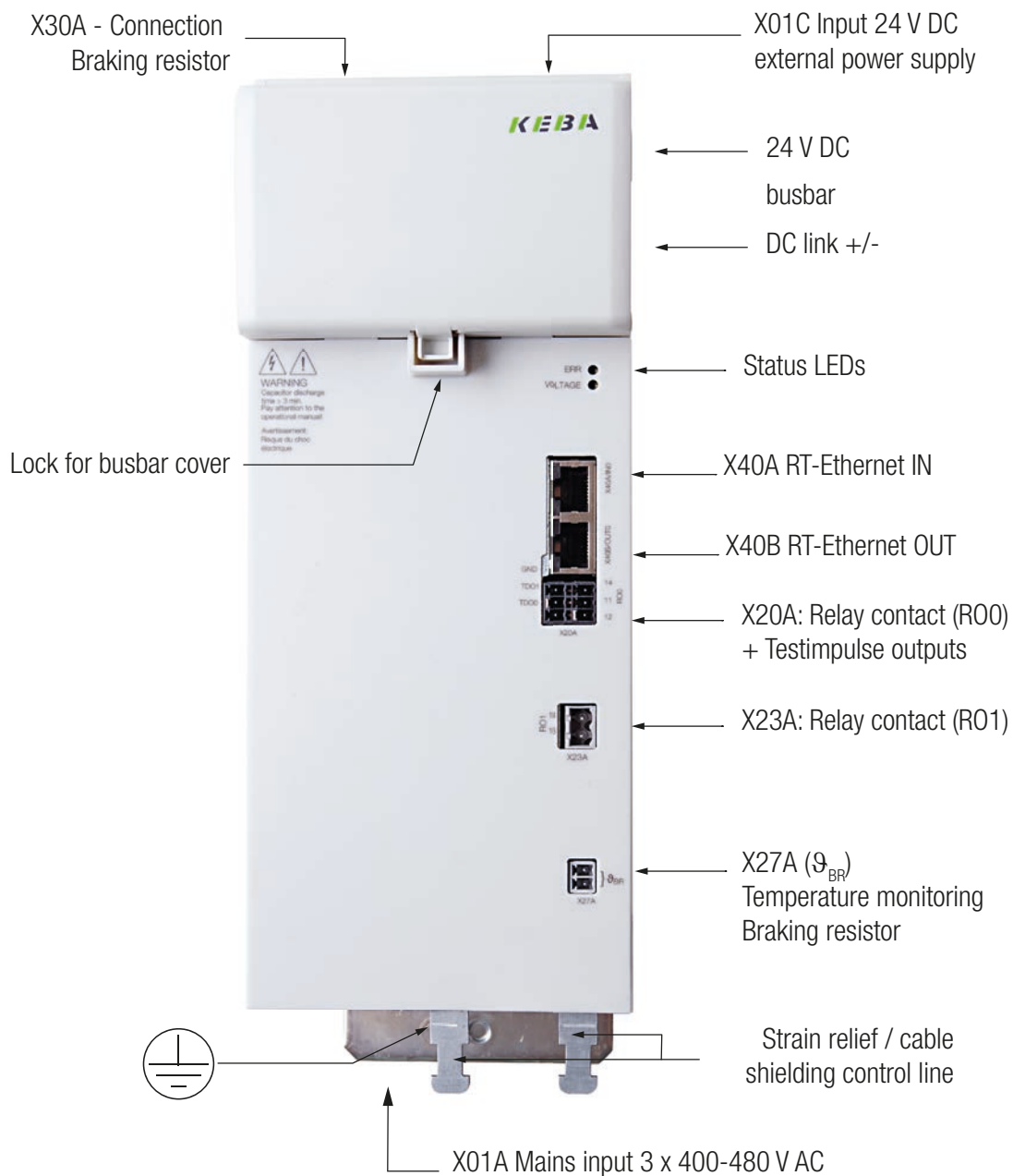

2

*) Field test version, UL acceptance in preparation



NOTE:

You will find descriptions and specifications for the above stated connections in the Operation Manual KeDrive D3-DP 30x Supply Unit BG1+2 (ID. no.: 1404.201B.x-xx).

Included in the scope of supply		For details see
Supply unit	D3-DP 301/x-37xx	Chapter 2.2.7
Busbar elements	For 24 V DC supply and DC link power supply	-
Documentation	Document set	Chapter 7.2
Optional (not included in the scope of supply)		
Connector set	For control and power connections	Chapter 2.2.9

2.2.4 Overview of the connections, KeDrive D3-DP 301 supply unit (BG3)

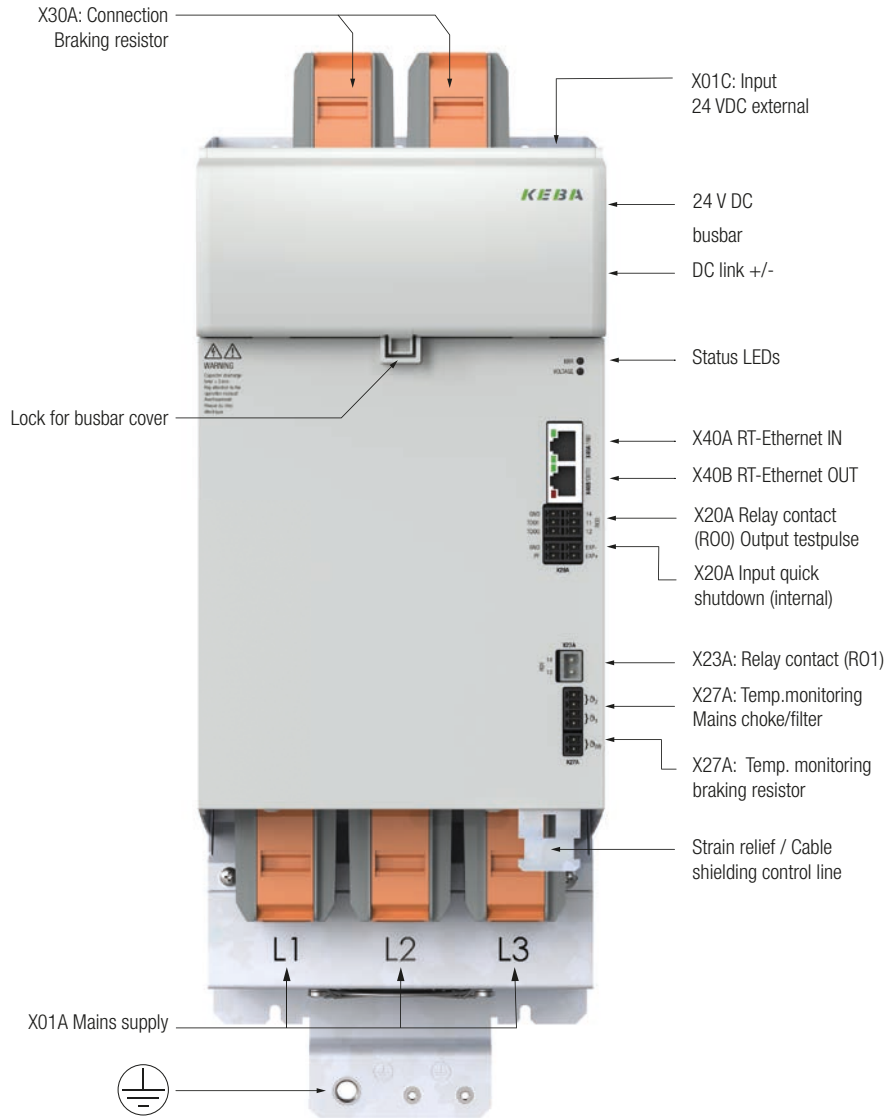

NOTE:

You will find descriptions and specifications for the above stated connections in the Operation Manual KeDrive D3-DP 301 Supply Unit BG3+4 (ID. no.: 1804.201B.X).

Included in the scope of supply		For details see
Supply unit	D3-DP 301/x-45xx and D3-DP 301/x-90xx	Chapter 2.2.7
Busbar elements	For 24 V DC supply and DC link power supply	-
Documentation	Document set	Chapter 7.2
Optional (not included in the scope of supply)		
Connector set	For control and power connections	Chapter 2.2.9

2.2.5 Overview of the connections, KeDrive D3-DP 301 supply unit (BG4)

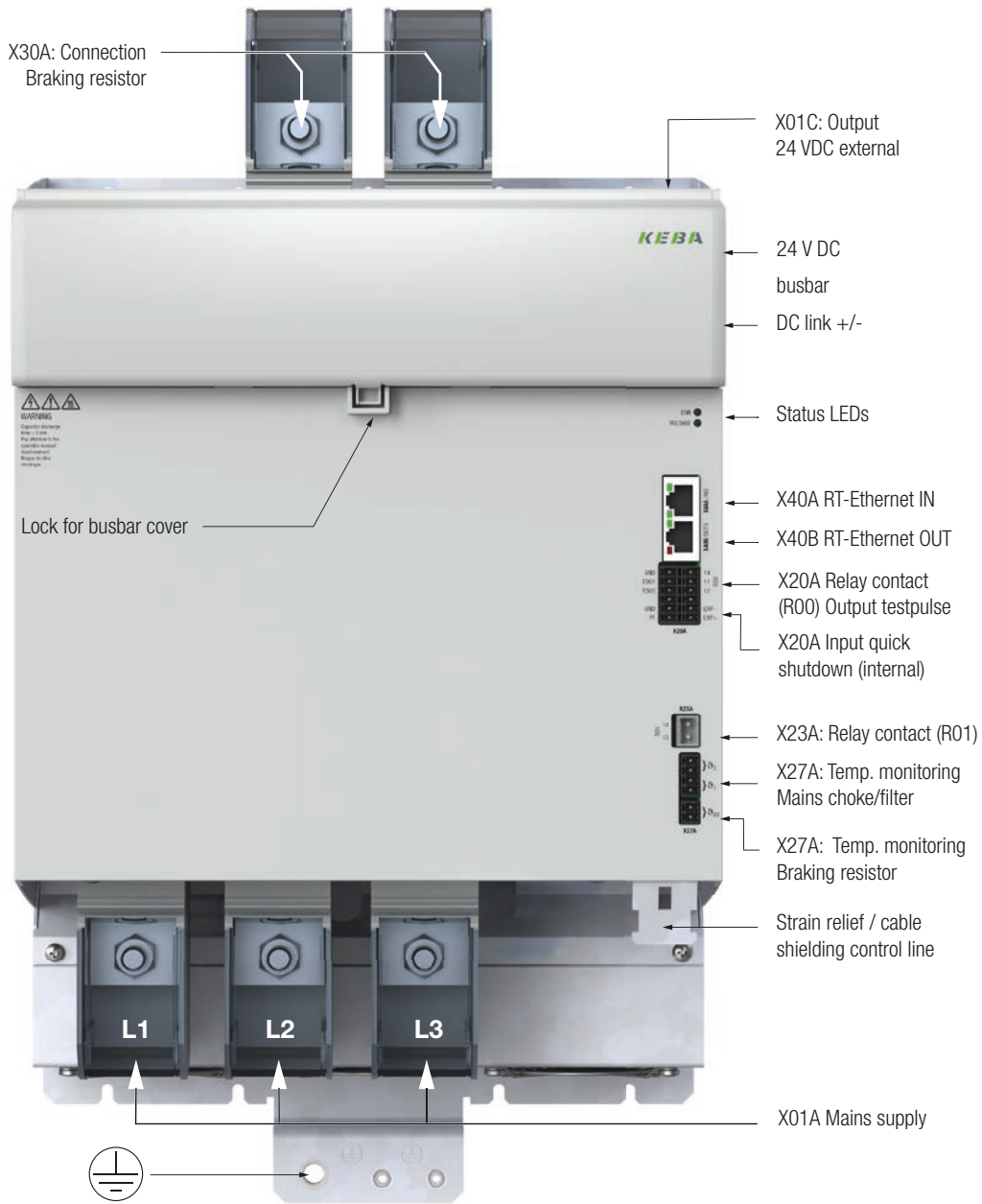

2



NOTE:

You will find descriptions and specifications for the above stated connections in the Operation Manual KeDrive D3-DP 301 Supply Unit BG3+4 (ID. no.: 1804.201B.x).

Included in the scope of supply		For details see
Supply unit	D3-DP 301/A-A2xx or D3-DP 301/C-A2xx	Chapter 2.2.7
Busbar elements	For 24 V DC supply and DC link power supply, pre-assembled	-
Documentation	Document set	Chapter 7.2
Optional (not included in the scope of supply)		
Connector set	For control and power connections	Chapter 2.2.9

2.2.6 Order code, KeDrive D3-DP 30x supply unit

The article designation provides information about the related variant of the supply unit delivered. You will find the significance of the individual characters of the order code in the column on the left.

	D3 - DP	3	0	0	/	A	-	4	5	0	0	-	0	0	0	1	-	0	0	0	0	
Module type	Supply module																					
Product line																						
Type of supply	0: Passive																					
Supply	0: 3 x 230 - 480 VAC ¹⁾ 1: 3 x 400 - 480 VAC																					
Cooling	A: Heat sink B: Cooling plate ¹⁾ C: Liquid cooling ²⁾																					
Power	10: 10 kW 22: 22 kW 37: 37 kW ⁴⁾ 45: 45 kW 90: 90 kW A2: 120 kW / 140 kW [*]																					
Control supply 24 VDC	0: None 4: 24 VDC/ 20 A integrated ¹⁾ 5: 24 VDC/ 20 A integrated with power failure bridging ¹⁾																					
Braking resistor	0: External 1: Integrated (not possible for variant D3-DP 300/B: cooling plate) 2: Supply module as slave variant (no braking resistor) ³⁾																					
Options	0: Not including protective coating 1: Including protective coating																					
Hardware version	1: UL																					
Models	00: Not incl. product documentation ^{**)} 01: Incl. product documentation (standard variant) 02: Incl. connector sets, not incl. product documentation ^{**)} 03: Incl. connector sets, incl. product documentation																					
Field bus	0: RT-Ethernet coupler & cross-communication																					
Reserved																						

^{*)} Power for liquid-cooled variant (D3-DP 301/C-A2xx) ^{**)} Only contract customers
¹⁾ Only BG1+2 ²⁾ Only BG3+4 ³⁾ Only BG4 ⁴⁾ Field test version, UL acceptance in preparation



NOTE:

A maximum of 9 modules are allowed to be connected and operated in the axis group (D3-DP, D3-DC, D3-DA, D3-DE...). Note: on the version with external braking resistor, the supply unit can only be operated **with** braking resistor.

Order as accessory

- Connector set - supply unit, see chapter Chapter 2.2.9

2.2.7 Technical data, KeDrive D3-DP 30x supply unit

Power and size overview, supply units

Device	Continuous output power	Size	Supply voltage	Brake chopper	Control supply	Quick shutdown	For details see
D3-DP300/A-10 D3-DP300/B-10	10 kW	BG1 310 x 55 x 241 mm	3 x 230 - 480 V AC	Yes (int. resistance optional)	Integrated	No	Table 2.2
D3-DP300/A-22 D3-DP300/B-22	22 kW	BG2 310 x 110 x 241 mm	3 x 230 - 480 V AC	Yes (int. resistance optional)	Integrated	No	Table 2.3
D3-DP300/A-37	37 kW	BG2 336 x 110 x 241 mm	3 x 400 - 480 V AC	Yes (only external resistance)	Only external	No	Table 2.4
D3-DP300/A-45 D3-DP300/C-45	45 kW	BG3 458 x 164 x 251 mm	3 x 400 - 480 V AC	Yes (only external resistance)	Only external	Yes	Table 2.5
D3-DP300/A-90 D3-DP300/C-90	90 kW	BG3 458 x 164 x 251 mm	3 x 400 - 480 V AC	Yes (only external resistance)	Only external	Yes	
D3-DP300/A-A2 D3-DP300/C-A2	120 kW 140 kW	BG4 490 x 274 x 252 mm	3 x 400 - 480 V AC	Yes (only external resistance)	Only external	Yes	Table 2.7
Common characteristics							
Precharging	With charging current limiting						
Mains contactor	Operation of an external mains contactor via integrated relay contact						
Mains filter	External combined mains filter						
Test outputs	2 (OSSD output signals are used to control the safe, digital inputs and test the axis module wiring for short-circuit and cross-circuit)						
Interfaces	Internal cross-communication						

Table 2.1 Overview, supply units, passive



NOTE:

Only operate supply unit with braking resistor! Take into account for model with external braking resistor!



NOTE:

A maximum of 9 modules are allowed to be connected and operated in the axis group (D3-DP, D3-DC, D3-DA, D3-DE...). If the number of axes in the application is greater, additional supply units must be provided.

Technical data, D3-DP 300 supply unit BG1

Device	D3-DP 300/A-10xx / D3-DP 300/B-10xx		
Input, mains side			
Mains voltage $U_N \pm 10\%$	3 x 230 V AC	3 x 400 V AC	3 x 480 V AC
Continuous current [$A_{AC\text{eff}}$], typical	23 A_{eff}	23 A_{eff}	19 A_{eff}
Peak current [A_{AC}], typical	46 A_{eff}	46 A_{eff}	38 A_{eff}
Continuous power, typical (dependent of the mains impedance)	9 kVA	16 kVA	
Rectifier power dissipation, typical	50 W		
Asymmetry of the mains voltage	$\pm 3\%$ max.		
Frequency	50-60 Hz $\pm 10\%$		
Max. cable cross-section X12	1.5 ... 6 mm ² (fine-stranded cable with/without ferrules) mm ²		
DC link output			
DC link voltage, typical	325 V DC	565 V DC	678 V DC
Continuous current	18 A DC	18 A DC	15 ADC
Peak current 2 x IN for 1 s mains choke not required	36 A DC	36 A DC	30 ADC
Continuous power PN	5.8 kW	10 kW	10 kW
Peak power 2 x PN for 1 s	11.6 kW	20 kW	20 kW
DC link capacitance	330 μF		
Maximum permissible DC link capacitance KeDrive D3-DP 30x BG1	2000 μF		
Power dissipation Prated in the interior	85 W		
Brake chopper power electronics			
Brake chopper switching threshold	411 V	652 V	765 V
Overvoltage protection	446 V	687 V	800 V
Continuous braking power [kW]	1.8 kW	3 kW	3 kW
Peak braking power for max. 0.5 s ²⁾	8 kW	13 kW	16 kW
Maximum ohmic resistance of an externally connected braking resistor	60 Ω	90 Ω	90 Ω
Minimum ohmic resistance of an externally connected braking resistor ³⁾	21 Ω	33 Ω	38 Ω
Supply unit with integrated braking resistor: (model S0 CM-P.xxxx.1xx.x)			
Continuous braking power	75 W		
Peak braking power for max. 0.5 s ²⁾	3 kW		
Ohmic resistance of the integrated braking resistor	56 Ω		

2) After this time shutdown is initiated based on $I^2 \times t$; 3) Including tolerance

Table 2.2 Technical data, KeDrive D3-DP 30x supply unit BG1



NOTE:

You will find more information about mounting in the Operation Manual KeDrive D3-DP 30x Supply Unit (ID no.: 1400.201B.x-xx).

Technical data, KeDrive D3-DP 30x supply unit BG2 (22 kW)

Device	D3-DP 300/A-22xx / D3-DP 300/B-22xx		
Input, mains side			
Mains voltage $U_N \pm 10\%$	3 x 230 V AC	3 x 400 V AC	3 x 480 V AC
Continuous current [$A_{AC\ eff}$], typical	46 A	46 A	38 A
Peak current [A_{AC}], typical	92 A	92 A	76 A
Continuous power, typical (dependent of the mains impedance)	18.5 kVA	32 kVA	
Rectifier power dissipation	110 W		
Asymmetry of the mains voltage	$\pm 3\%$ max.		
Frequency	50-60 Hz $\pm 10\%$		
Max. cable cross-section of the terminals X12	1.5 ... 16 mm ² (fine-stranded cable with/without ferrules)		
DC link output			
DC link voltage, typical	325 V DC	565 V DC	678 V DC
Continuous current	39 ADC	39 ADC	32 ADC
Peak current $2 \times I_N$ for 1 s mains choke not required	78 ADC	78 ADC	64 ADC
Continuous power P_N	12.5 kW	22 kW	
Peak power $2 \times P_N$ for 1 s	25 kW	44 kW	
DC link capacitance	840 μ F		
Maximum permissible DC link capacitance KeDrive D3-DP 30x BG2	4000 μ F		
Power dissipation P_{rated} in the interior	130 W		
Brake chopper power electronics			
Brake chopper switching threshold	411 V	652 V	765 V
Overvoltage protection	446 V	687 V	800 V
Continuous braking power	3.5 kW	6 kW	6 kW
Peak braking power for max. 0.5 s ²⁾	20 kW	28 kW	30 kW
Maximum ohmic resistance of an externally connected braking resistor	50 Ω	90 Ω	90 Ω
Minimum ohmic resistance of an externally connected braking resistor ³⁾	8 Ω	15 Ω	20 Ω
Supply unit "with integrated braking resistor" (version KeDrive D3-DP 30x.xxxx.11xx.x)			
Continuous braking power	200 W		
Peak braking power for max. 0.5 s ²⁾	6 kW		
Ohmic resistance of the integrated braking resistor	28 Ω		

2) After this time shutdown based on $I^2 \times t$; 3) Including tolerance

Table 2.3 Technical data, KeDrive D3-DP 30x supply unit BG2

**NOTE:**

You will find more information about mounting in the Operation Manual KeDrive D3-DP 30x Supply Unit (ID no.: 1404.201B.x-xx).

Technical data, KeDrive D3-DP 30x supply unit BG2 (37 kW)

Device	D3-DP 300/A-37xx	
Input, mains side		
Mains voltage $U_N \pm 10\%$	3 x 400 V AC	3 x 480 V AC
Continuous current $[A_{AC\ eff}]$, typical	75 A ¹⁾ / 79 A ²⁾	63 A ¹⁾ / 70 A ²⁾
Peak current $[A_{AC}]$, typical	120 A	106 A
Continuous power, typical (dependent of the mains impedance)	54 kVA	
Rectifier power dissipation	200 W	
Asymmetry of the mains voltage	±3% max.	
Frequency	50-60 Hz ± 10%	
Max. cable cross-section of the terminals X12	1.5 ... 35 mm ² (fine-stranded cable with/without ferrules)	
DC link output		
DC link voltage, typical	565 V DC	678 V DC
Continuous current	66 A ¹⁾ / 73 A ²⁾	55 A ¹⁾ / 61 A ²⁾
Peak current $2 \times I_N$ for 10 s	115 ADC	96 ADC
Peak current $2 \times I_N$ for 0.5 s	212 ADC	177 ADC
Continuous power P_N	37 kW ¹⁾ / 41 kW ²⁾	
Peak power $2 \times P_N$ for 10 s	65 kW	
Peak power $2 \times P_N$ for 0.5 s	120 kW	
DC link capacitance	1500 µF	
Required total DC link capacitance for continuous power	5500 µF ¹⁾ / 6150 µF ²⁾	
Power dissipation P_{rated} in the interior	130 W	
Brake chopper power electronics		
Brake chopper switching threshold	652 V	765 V
Overvoltage protection	687 V	800 V
Continuous braking power	10 kW	10 kW
Peak braking power for max. 0.5 s ²⁾	55 kW	62 kW
Maximum ohmic resistance of an externally connected braking resistor	50 Ω	50 Ω
Minimum ohmic resistance of an externally connected braking resistor ³⁾	7 Ω	8.5 Ω

1) Without mains choke $SCCR \leq 5\text{ kA}$ 2) With mains choke $SCCR > 5\text{ kA}$ 3) Load-dependent

Table 2.4 Technical data, KeDrive D3-DP 30x supply unit BG2 / 37 kW



NOTE:

You will find more information about mounting in the Operation Manual KeDrive D3-DP 30x Supply Unit (ID no.: 1404.201B.x-xx).

Technical data, KeDrive D3-DP 30x supply unit BG3

Device	Unit	D3-DP 301/A-45xx D3-DP 301/C-45xx				D3-DP 301/A-90xx D3-DP 301/C-90xx			
		3 x 400	3 x 480	3 x 400	3 x 480	3 x 400	3 x 480	3 x 400	3 x 480
Input, mains side									
Mains voltage [AC] U_N	V AC	3 x 400	3 x 480	3 x 400	3 x 480	3 x 400	3 x 480	3 x 400	3 x 480
Tolerance on the supply voltage		± 10% of U_N							
Continuous current, typical [AC]	A eff	88	77	88	77	155	135	155	135
Peak current [AC]	A eff	176	154	176	154	310	270	310	270
Continuous power, typical	kVA	60		60		111		111	
Rectifier power dissipation, typical	W	230		230		440		440	
Asymmetry of the mains voltage		±3% max.							
Frequency	Hz	50-60 Hz ± 10%							
Maximum cable cross-section on X8		Max. 95 mm ² (stranded cable without ferrule)							
DC link output									
DC link voltage [DC]	V	565	678	565	678 V	565	678	565	678
Continuous current [DC]	A	80	67	80	67	160	133	160	133
Peak current [DC] 2 x I_N for 10 s	A	160	134	160	134	320	266	320	266
Continuous power P_N	kW	45	45	45	45	90	90	90	90
Peak power 2 x P_N for 10 s	kW	90	90	90	90	180	180	180	180
DC link capacitance	µF	650				975			
Maximum permissible DC link capacitance in the axis group	µF	15000				30000			
Total DC link capacitance required in the axis group for P_N :		4500 µF		4500 µF		9000 µF		9000 µF	
NOTE:									
In the overall axis group, a DC link capacitance of 100 µF/kW (for 3 x 400 V), referred to the highest rated power that occurs, must be provided.									
The root mean square of the active power for a load cycle is defined as the active power.									
Power dissipation P_{rated} in the interior	W	Air-cooled: 170 Liquid-cooled: 130				Air-cooled: 280 Liquid-cooled: 240			
24 V control voltage input									
Power consumption, typical	W	12*)							
Input voltage [DC]	V	24 V DC ±10%							

*) The power consumption of the devices in the row is additional to this figure.

Table 2.5 Technical data, KeDrive D3-DP 30x supply unit BG3

Technical data, brake chopper BG3

Device	Unit	D3-DP 301/x-45xx		D3-DP 301/x-90xx	
Mains voltage [AC]	V	400	480	400	480
Brake chopper power electronics					
Brake chopper switching threshold	V	652	765	652	765
Overvoltage protection	V	687	800	687	800
Continuous braking power	kW	10	10	20	20
Peak braking power for max. 10 s *)	kW	68	94	121	167
Maximum ohmic resistance of an externally connected braking resistor	Ω	45	45	45	45
Minimum ohmic resistance of an externally connected braking resistor **	Ω	6.2	6.2	3.5	3.5

*) After this time shutdown is initiated based on Pxt; **) Including tolerance

Table 2.6 Technical data, brake chopper, KeDrive D3-DP 30x supply unit BG3



NOTE:

You will find more information about mounting in the Operation Manual KeDrive D3-DP 30x Supply Unit (ID no.: 1804.201B.x-xx).

Technical data, KeDrive D3-DP 30x supply unit BG4

Device	Unit	D3-DP 301/x-A2xx master				D3-DP301/x-A22x slave			
		.../A-A2xx		.../C-A2xx		../A-A22x		.../C-A22x	
Input, mains side									
Mains voltage [AC] U_N	V	3 x 400	3 x 480	3 x 400	3 x 480	3 x 400	3 x 480	3 x 400	3 x 480
Tolerance on the supply voltage	%	± 10% of U_N							
Continuous current [AC], typical	A_{eff}	196	163	226	188	196	163	196	163
Peak current [AC], typical	A_{eff}	392	326	392	326	392	326	392	326
Continuous power, typical	kVA	159		159		159		159	
Rectifier power dissipation	W	580		580		580		580	
Asymmetry of the mains voltage	%	±3% max.							
Frequency	Hz	50-60 Hz ± 10%							
Maximum cable cross-section on X8	mm ²	150 mm ²							
DC link output									
DC link voltage [DC]	V	565	678	565	678	565	678	565	678
Continuous current	A [DC]	212	177	248	183	212	177	212	177
Peak current 2 x I_N for 10 s	A [DC]	424		424		424		424	
Continuous power P_N	kW	120*)		140*)		120*)		120*)	
Peak power 2 x P_N for 10 s	kW	240*)		240*)		240*)		240*)	
DC link capacitance	µF	1625							
Maximum permissible DC link capacitance in the axis group	µF	40000							
Total DC link capacitance required in the axis group for PN:		12000 µF		14000 µF		12000 µF		14000 µF	
In the overall axis group, a DC link capacitance of 100 µF/kW (for 3 x 400 V), referred to the highest rated power that occurs, must be provided. The root mean square of the active power for a load cycle is defined as the active power.									
Power dissipation P_{rated} in the interior	W	Air-cooled: 460 Liquid-cooled: 350							

*) During master/slave operation with reduced power.

Table 2.7 Technical data, KeDrive D3-DP 30x master BG4 and KeDrive D3-DP 30x slave BG4

Device	Unit	D3-DP 301/A-A2xx D3-DP 301/C-A2xx	
Mains voltage	V AC	400 V AC	480 V AC
Brake chopper power electronics			
Brake chopper switching threshold	V	652	765
Overvoltage protection	V	687	800
Continuous braking power	kW	25	25
Peak braking power for max. 10 s *)	kW	177	244
Maximum ohmic resistance of an externally connected braking resistor	Ω	28	28
Minimum ohmic resistance of an externally connected braking resistor **)	Ω	2.4	2.4

*) After this time shutdown is initiated based on Pxt.

**) Including tolerance

Table 2.8 Brake chopper supply unit, KeDrive D3-DP 30x BG4

**Note:**

Not for supply unit KeDrive D3-DP 30x slave (D3-DP 301/x-xx02).

2.2.8 Installation and dimensions, KeDrive D3-DP 30x supply unit

D3-DP 300/x-10xx supply unit BG1

Device type	D3-DP 30x/A-10xx	D3-DP 30x/B-10xx
Cooling method	Air-cooled (heat sink)	Cold plate
Weight	2.65 kg	2.2 kg
Mounting method	Vertical mounting with unhindered air flow	Vertical mounting on thermally conductive film
Side clearance	0 mm	0 mm
B (width)	55 mm	54.5 mm
H (height)	310 mm	310 mm
T (depth) / T1	241 / 222 mm ²⁾	189 / 170 mm ²⁾
C	299 mm	299 mm
C1	6 mm	6 mm
A	27.5 mm	27.5 mm
A1	-	-
D	5 mm	5 mm
Screws	2x M4	2x M4

Dimensional sketches

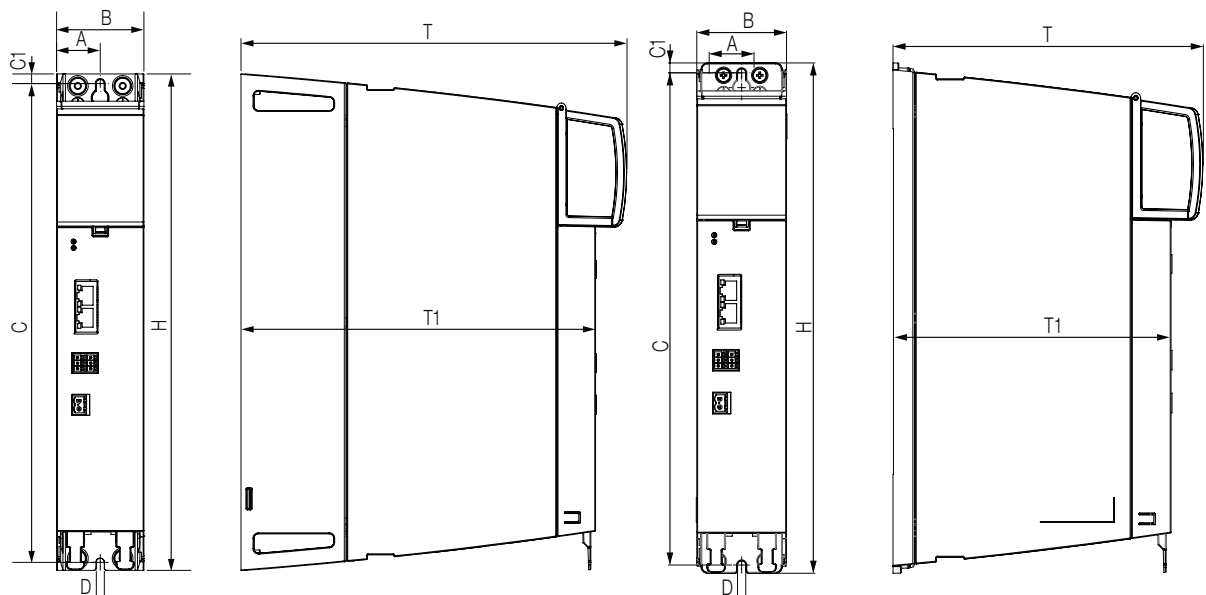

2) Without terminals/connections

Table 2.9 Dimensions, KeDrive D3-DP 30x supply unit BG1



NOTE:

- The supply unit is fitted to the left of the axis controllers.
- Fit the axis controller with the highest power next to the supply unit (for double-axis and triple-axis controllers it is the total power that counts).

You will find more information about mounting in the Operation Manual KeDrive D3-DP 30x Supply Unit (ID no.: 1400.201B.x-xx).

D3-DP 300/x-22xx supply unit BG2

Device type	D3-DP 30x/A-22xx	D3-DP 30x/A-37xx	D3-DP 30x/B-22xx
Cooling method	Air-cooled (heat sink)		Cold plate
Weight	5.1 kg	6.1 kg	4.2 kg
Mounting method	Vertical mounting, direct butt mounting with unhindered air flow		Vertical mounting on thermally conductive film
Side clearance	0 mm		0 mm
B (width)	110 mm		109 mm
H (height)	310 mm	336	310 mm
T (depth) / T1	241 (222 mm) ²⁾		189 / 170 mm ²⁾
C	299 mm		299 mm
C1	6 mm		6 mm
A	27.5 mm		27.5 mm
A1	55		-
D	5 mm		5 mm
Screws	4 x M4		4 x M4

Dimensional sketches

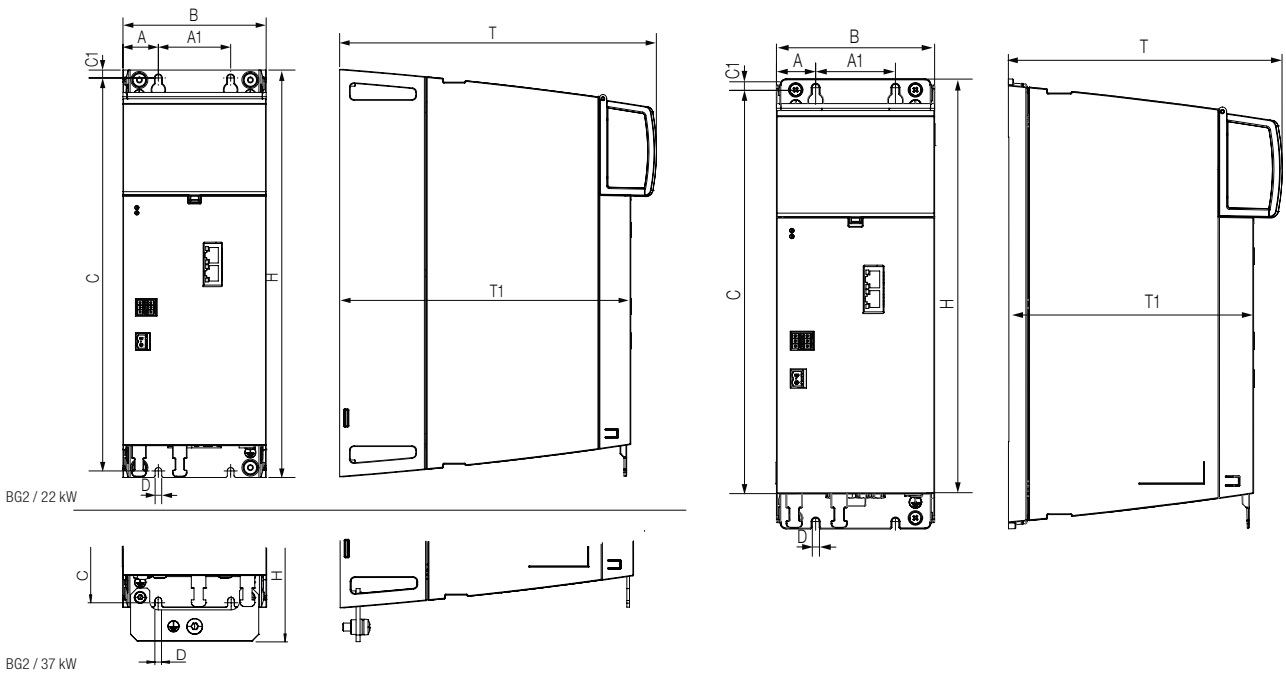

²⁾ Without terminals/connections

Table 2.10 Dimensions, KeDrive D3-DP 30x supply unit BG2



NOTE:

- The supply unit is fitted to the left of the axis controllers.
- Fit the axis controller with the highest power next to the supply unit (for double-axis and triple-axis controllers it is the total power that counts).

You will find more information about mounting in the Operation Manual KeDrive D3-DP 30x Supply Unit (ID no.: 1400.201B.x-xx).

D3-DP 301/x-45xx and D3-DP 301/x-90xx supply unit BG3

Device type	D3-DP 301/A-45xx / D3-DP 301/A-90xx	D3-DP 301/C-45xx / D3-DP 301/C-90xx
Cooling method	Air-cooled (heat sink)	Liquid-cooled
Mounting method	Vertical mounting with unhindered air flow	Vertical mounting, coolant connection from rear
Weight	Approx. 13 kg	Approx. 13 kg
Side clearance	Direct butt mounting	Direct butt mounting
B (width)	164 mm	164 mm
H (height)	457.5 mm	457.5 mm
C1 / C2	378 / 6 mm	378 / 6 mm
H3 / H4	430 / 390 mm	430 / 390 mm
T (total depth)	251 mm ¹⁾	251 mm ¹⁾
T1/ T2	222 / - mm	222 / 75.2 mm
A / A1 / A2	27 / 110 / 55 mm	27 / 110 / 55 mm
C	4.8 mm	4.8 mm
D / D1	80 / - mm	80 / 35 mm (bore for pipe fitting)
F / G	- / -	70 / 47 mm
Screws	5 x M4	

Dimensional sketches

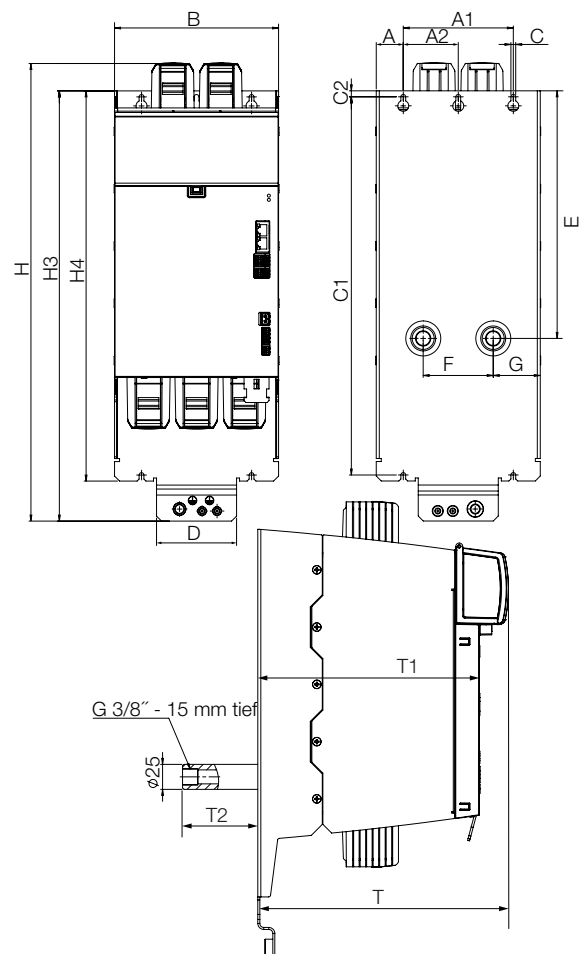
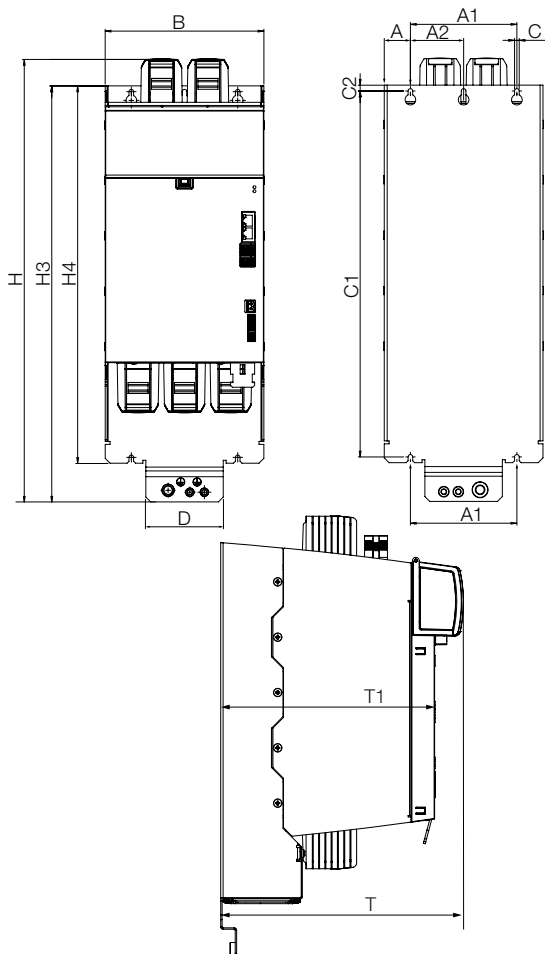

¹⁾ Without terminals/connections

Table 2.11 Dimensions, KeDrive D3-DP 30x supply unit BG3

KeDrive D3-DP 30x supply unit BG4

KeDriveD3-DP30x	D3-DP 301/A-A2xx	D3-DP 30x/C-A2xx
Cooling method	Air-cooled (heat sink)	Liquid-cooled
Mounting method	Vertical mounting with unhindered air flow	Vertical mounting, coolant connection from rear
Weight	Approx. 17 kg	Approx. 17 kg
Side clearance	Direct butt mounting	Direct butt mounting
B (width)	274 mm	274 mm
H (height)	489.5 mm	489.5 mm
C1 / C2	378 / 6 mm	378 / 6 mm
H3 / H4	430 / 390 mm	430 / 390 mm
T (total depth)	251 mm ¹⁾	251 mm ¹⁾
T1 / T2	222 / - mm	222 / 75.2 mm
A / A1 / A2	27 / 220 / 55 mm	27 / 220 / 55 mm
C	4.8 mm	4.8 mm
D / D1	80 / - mm	80 / 35 mm (bore for pipe fitting)
F / G	- / -	70 / 102 mm
Screws D	9 x M4	9 x M4

Dimensional sketches

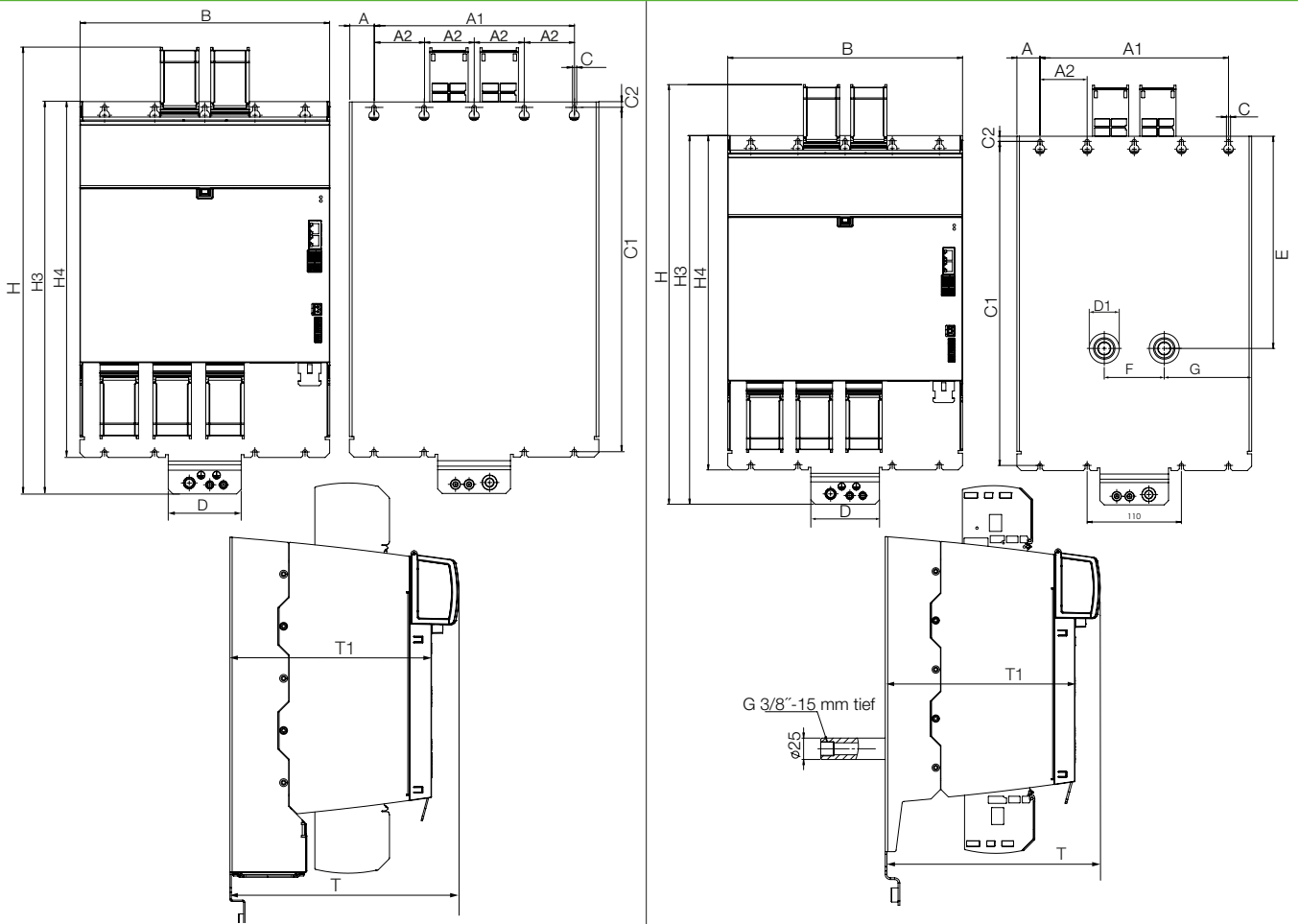

¹⁾ Without terminals/connections

Table 2.12 Dimensions, KeDrive D3-DP 30x supply unit BG4

2.2.9 Connector sets, KeDrive D3-DP 30x supply units

KeDrive D3-DP 30x supply unit BG1+2

Figure	Order designation	Explanation
	<p>D3-XT 220/B for supply unit BG1: D3-DP 300/x-10xx</p>	<p>1 = X23A- (R01) - Relay output for control of main contactor (terminal) 2 = X01C Input/output 24 V DC 3 = X30A - Connection for braking resistor incl. thermal contact (via terminals) 4 = X20A - Digital outputs + relay output (RO) 5 = X01A - Mains input (L1, L2, L3 / 3 x 400 V AC) - for DC link power supply to the axis controllers 6 = 2x EMC cable clamp 10-16 mm and 16-27 mm</p>
	<p>D3-XT 221/B for supply unit BG2; D3-DP 300/x-22xx</p>	<p>1 = X23A- (R01) - Relay output for control of main contactor (terminal) 2 = X01C Input/output 24 V DC 3 = X30A - Connection for braking resistor incl. thermal contact (via terminals) 4 = X20A - Digital outputs + relay output (RO) 5 = X01A - Mains input (L1, L2, L3 / 3 x 400 V AC) - for DC link power supply to the axis controllers. 6 = 2x EMC cable clamp 10-16 mm and 16-27 mm</p>
	<p>D3-XT 220/C connector for mains input integrated switched-mode power supply D3-DP 30x/x-xx4x D3-DP 30x/x-xx5x</p>	<p>5 = X01B - Switched-mode power supply mains input (L1, L2 / 2 x 400 V AC) - for 24 V control supply</p>

2

Figure	Order designation	Explanation
	<p>D3-XT 220/E connector set for D3-DP (BG1) with int. BR</p>	<p>1 = X23A- (R01) - Relay output for control of main contactor (terminal) 2 = X01C Input/output 24 V DC 3 = X20A - Digital outputs + relay output (RO0) 4 = X01A - Mains input (L1, L2, L3 / 3 x 400 V AC) - for DC link power supply to the axis controllers 5 = 2x EMC cable clamp 10-16 mm and 16-27 mm</p>
	<p>221/C connector set for D3-DP (BG2) with int. BR</p>	<p>1 = X23A- (R01) - Relay output for control of main contactor (terminal) 2 = X01C Input/output 24 V DC 3 = X20A - Digital outputs + relay output (RO0) 4 = X01A - Mains input (L1, L2, L3 / 3 x 400 V AC) - for DC link power supply to the axis controllers 5 = 2x EMC cable clamp 10-16 mm and 16-27 mm</p>
	<p>221/D connector set for D3-DP (BG2) 37 kW</p>	<p>1 = X01C Input 24 V DC control supply, external) 2 = X30A - Connection for braking resistor 3 = X20A: Relay contact (RO0)+ Test pulse outputs 4 = X23A: Relay contact (RO1) 5 = X27A (9_{BR})Temp. monitoring-braking resistor 6 = X01A Mains input 3 x 400-480 V AC 7 = 2x EMC cable clamp 10-16 mm and 16-27 mm</p>

KeDrive D3-DP 30x supply unit BG3 and BG4

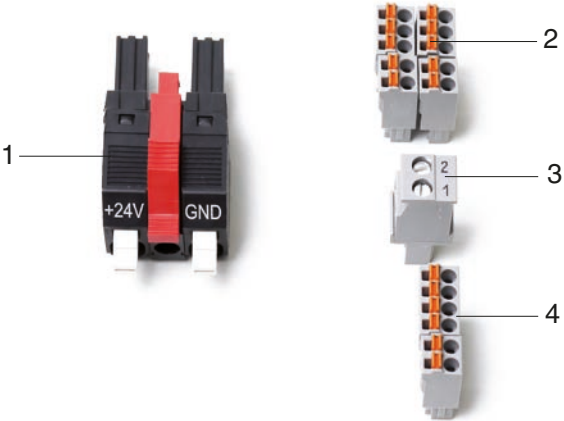
Figure	Order designation	Explanation
	<p>D3-XT 224/A for D3-DP 301/x-45 D3-DP 301/x-90 D3-DP 301/x-A2</p>	<p>1 = X01C - Input 24 V DC control supply 2 = X20A - Relay contact (R00), output for test pulse, input for quick shutdown (internal) 3 = X23A - Relay contact (R01) 4 = X27A - Temp. monitoring mains choke/filter, temp. monitoring braking resistor</p>

2

3 Active supply unit

3.1 System overview

Device	KeDrive D3-DL 300 charging module	KeDrive D3-DP 310 supply module
--------	-----------------------------------	---------------------------------

Fig.



3

Details	Devices upon request, limited approval for field test
Operation Manual	1804.208B.x

Energy-efficient drive technology

Active supply units make a significant contribution to the reduction of the energy and connection costs for a machine.

- Energy saving due to recovery of regenerative energy to the supply system.
- Reduction of the mains connection costs by means of active peak current limiting. The peak power is only drawn from the DC link
- The regulated DC link permits mains voltage-independent drive solutions and that worldwide.

The active supply unit consists of a charging module D3-DL 300 and a power-dependent supply module D3-DP 310.



NOTE:

The latest operation manuals and other documents are available in German, English and other languages and can be downloaded from our homepage

<https://www.keba.com/de/industrial-automation/service-support/downloads/doku-data-portal>

3.1.1 Overview of the connections, KeDrive D3-DL 300 charging module

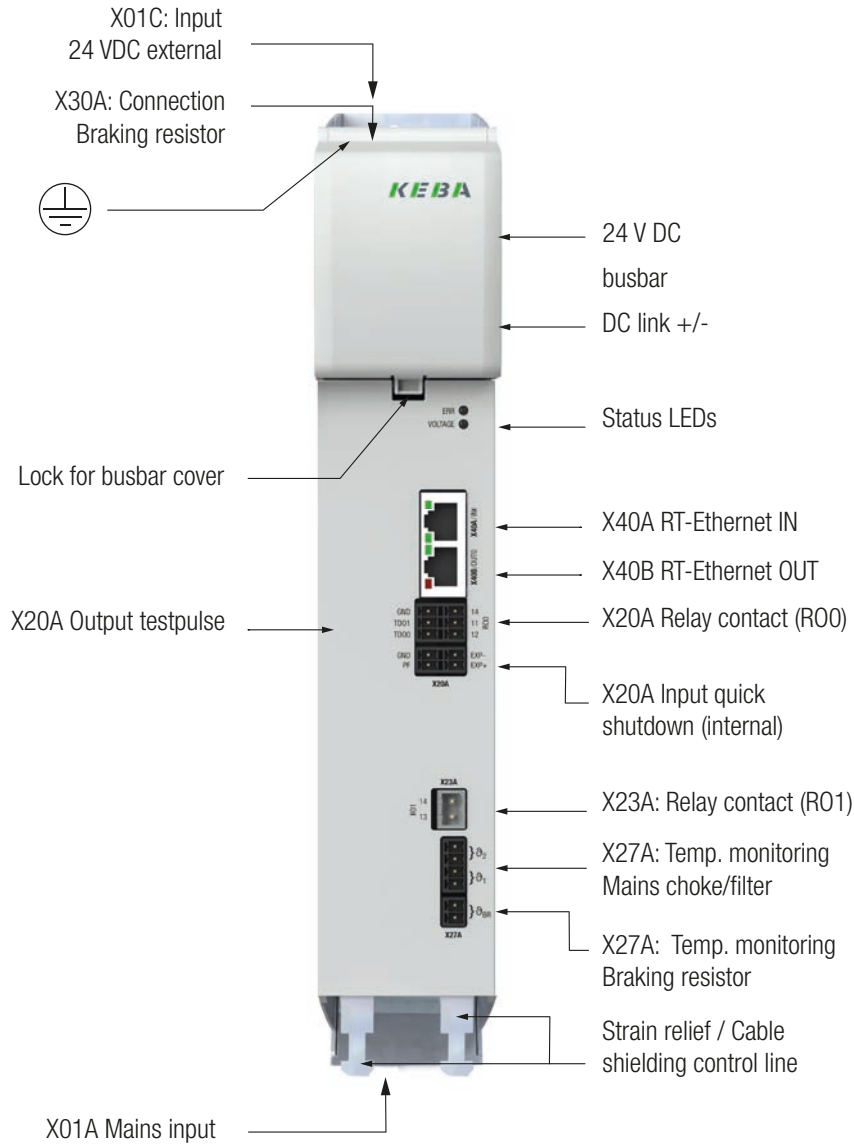

NOTE:

You will find descriptions and specifications for the above stated connections in the Operation Manual D3-DP 300 Supply Unit (ID. no.: 1804.208B.x-xx).

Included in the scope of supply		For details see
Charging module	KeDrive D3-DL 300	Chapter 3.1.5
Busbar elements	Busbar elements for DC link connection and 24 V control supply (in the separate bag of accessories)	-
Documentation	Document set	Chapter 7.2
Optional (not included in the scope of supply)		
Connector set	For control and power connections	Chapter 3.1

3.1.2 Overview of the connections, KeDrive D3-DP 310 supply modules

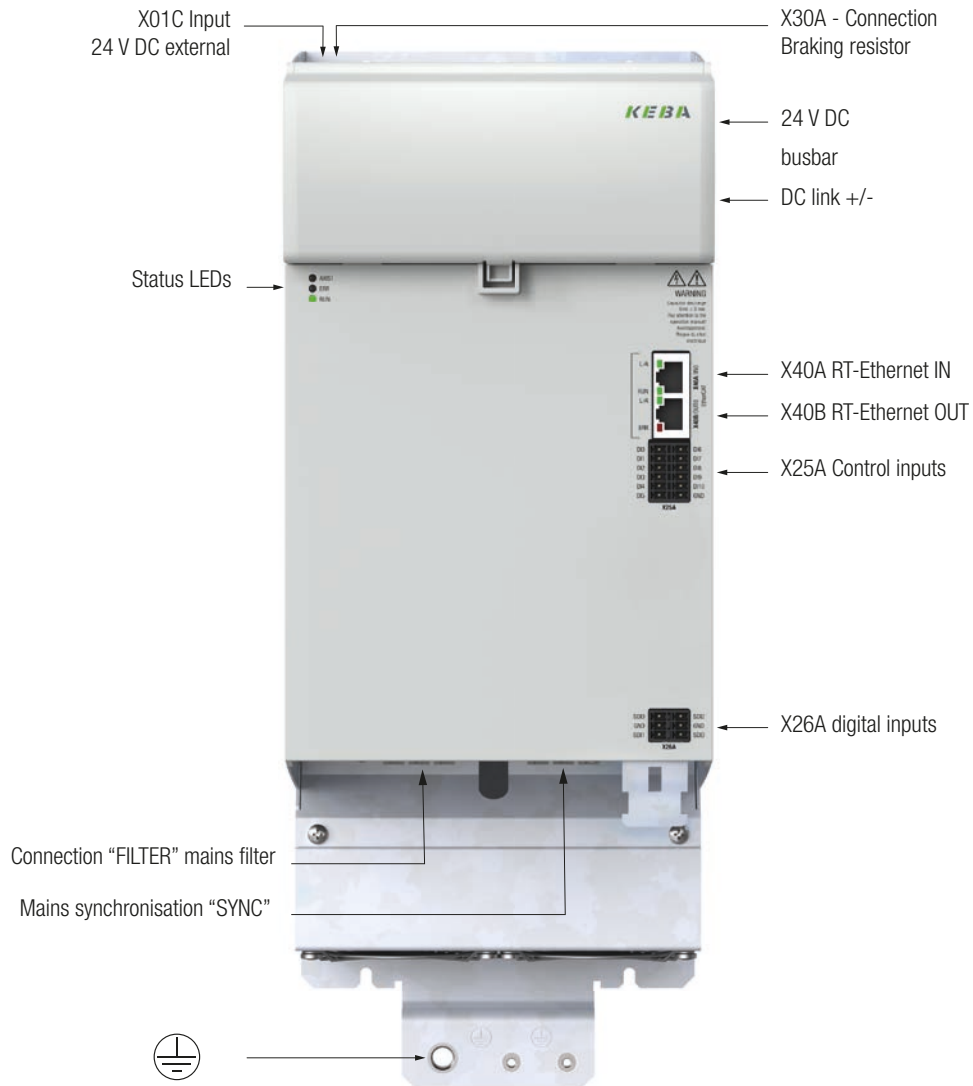

3



NOTE:

You will find descriptions and specifications for the above stated connections in the Operation Manual D3-DP 300 Supply Unit (ID. no.: 1804.208B.x-xx).

Included in the scope of supply		For details see
Supply module	KeDrive D3-DP 310/x-30xx or KeDrive D3-DP 310/x-55xx	Chapter 3.1.6
Busbar elements	Busbar elements for DC link connection and 24 V control supply (in the separate bag of accessories)	
Documentation	Document set	Chapter 7.2
Optional (not included in the scope of supply)		
Connector set	For control and power connections	Chapter 3.1

3.1.3 Order code, KeDrive D3-DL 300 charging module

	D3-	DL	3	0	0	/	A	-	A	1	0	0	-	0	0	0	1	-	0	0	0	0	
Module type	Charging module																						
Product line																							
Reserved																							
Power supply	0: 3 x 230 - 480 V AC																						
Cooling	A: Heat sink																						
Max. power BR	A1: 114 kW																						
Control supply 24 VDC	0: None																						
Braking resistor	0: External																						
Options	0: Not including protective coating 1: Including protective coating																						
Hardware version	0:																						
Models	00: Not incl. product documentation **) 01: Incl. product documentation (standard variant) 02: Incl. connector sets, not incl. product documentation **) 03: Incl. connector sets, incl. product documentation																						
Field bus	0: rt-Ethernet coupler and cross-communication																						
Reserved																							

**) Only contract customers

3.1.4 Order code, KeDrive D3-DP 310 supply modules

	D3-	DP	3	1	0	/	A	-	5	5	0	0	-	0	0	0	1	-	0	0	0	0	
Module type	Supply module																						
Product line																							
Type of supply	1: Active																						
Supply	0: 3 x 230 - 480 VAC																						
Cooling	A: Heat sink C: Liquid cooling																						
Power	30: 30 kW 55: 55 kW																						
Control supply 24 VDC	0: None																						
Braking resistor	0: None																						
Options	0: Not including protective coating 1: Including protective coating																						
Hardware version	0:																						
Models	00: Not incl. product documentation **) 01: Incl. product documentation (standard variant) 02: Incl. connector sets, not incl. product documentation **) 03: Incl. connector sets, incl. product documentation																						
Field bus	0: EtherCAT 1: POWERLINK* 2: PROFINET*																						
Reserved																							

**) Only contract customers

3.1.5 Technical data, KeDrive D3-DL 300 charging module

**Note:**

Until the type test is completed, all technical data are only calculated values and not assured characteristics!

Device	Unit	KeDrive D3-DL 300		
Input, mains side				
Nominal mains voltage U_N 3 x	V AC	230	400	480
Tolerance on the supply voltage	%	$\pm 10\%$ of U_N		
Asymmetry of the mains voltage	%	$\pm 3\%$ max.		
Frequency	Hz	50-60 Hz $\pm 10\%$		
Maximum cable cross-section on LINE IN	mm ²	1.5 ... 6		
DC link output				
DC link voltage	V DC	325	565	678
Precharging current	A DC	5		
Precharging power	kW	1.7	2.9	3.4
DC link capacitance only charging module	μ F	1		
Maximum permissible DC link capacitance	μ F	40000		
Power dissipation P_{rated} in the interior		Not yet available at the time of going to press		
Mains voltage	V AC	230	400	480
Brake chopper power electronics				
Brake chopper switching threshold	V DC	765	765	765
Overvoltage protection	V DC	800	800	800
Continuous braking power [kW]	kW	6	6	6
Peak braking power for max. 400 ms 1)	kW	115	115	115
Peak braking power for max. 10 s	kW	50	50	50
Maximum ohmic resistance of an externally connected braking resistor	Ω	90	90	90
Minimum ohmic resistance of an externally connected braking resistor 2)	Ω	5	5	5

1) After this time shutdown is initiated based on $P^2 \times t$

2) Including tolerance

Table 3.1 Technical data, KeDrive D3-DL 300

CAUTION!	Damage to the charging module due to overload in the DC link!
	<ul style="list-style-type: none"> Carelessness may result in significant damage. <p>The maximum overall capacitance of the multi-axis system DC link must not exceed the value stated.</p>

3.1.6 Technical data, KeDrive D3-DP 310 supply modules

**Note:**

Until the type test is completed, all technical data are only calculated values and not assured characteristics!

Device	Unit	KeDrive D3-DP 310/x-30xx			KeDrive D3-DP 310/x-55xx		
Input, mains side							
Nominal mains voltage U_N , 3 times	V AC	230	400	480	230	400	480
Tolerance on the supply voltage		$\pm 10\%$ of U_N					
Continuous current, typical	$A_{AC\ eff}$	42	42	36	79	79	67
Peak current, typical	$A_{AC\ eff}$	84	84	72	158	158	134
Continuous power, typical	kVA	17	30	30	32	56	56
Power dissipation, typical		Values not yet available at the time of going to press.					
Asymmetry of the mains voltage	%	$\pm 3\%$ max.					
Frequency	Hz	50-60 Hz $\pm 10\%$					
Maximum cable cross-section on LINE filter	mm ²	16			35		
Measurement of the mains voltage							
The mains voltage (L1, L2, L3) is measured on the connection "SYNC".							
Current consumption	A	< 0.5					
DC link output							
DC link voltage	V DC	380 - 750	600 - 750		380 - 750	600 - 750	
Continuous current	A DC	50	50	40	91	91	73
Peak current $2 \times I_N$ for 10 s	A DC	100	100	80	182	182	146
Continuous power P_N	kW	17	27		31	47	
Peak power $2 \times P_N$ for 10 s	kW	34	54		62	94	
DC link capacitance only ServoOne CM-A	μ F	2350					

Table 3.2 Technical data, KeDrive D3-DP 310

3.1.7 Dimensions, charging module and supply module (heat sink)

	KeDrive D3-DL 300 BG1	KeDrive D3-DP 310, BG3
Type	KeDrive D3-DL 300	KeDrive D3-DP 310/A-30xx KeDrive D3-DP 310/A-55xx
Weight	2.5 kg	10 kg
B (width)	54.5	164
H (height)	310	430
T (total depth)	241	251
T1	221	222
H1	299	378
H2		6
H3	-	390
A		27
A1		110
A2		55
C		4.8
D	-	80
Side clearance	Direct butt mounting	
Screws	2 x M4	5 x M4

Table 3.3 Dimensions, charging module and supply module (heat sink), all dimensions in mm

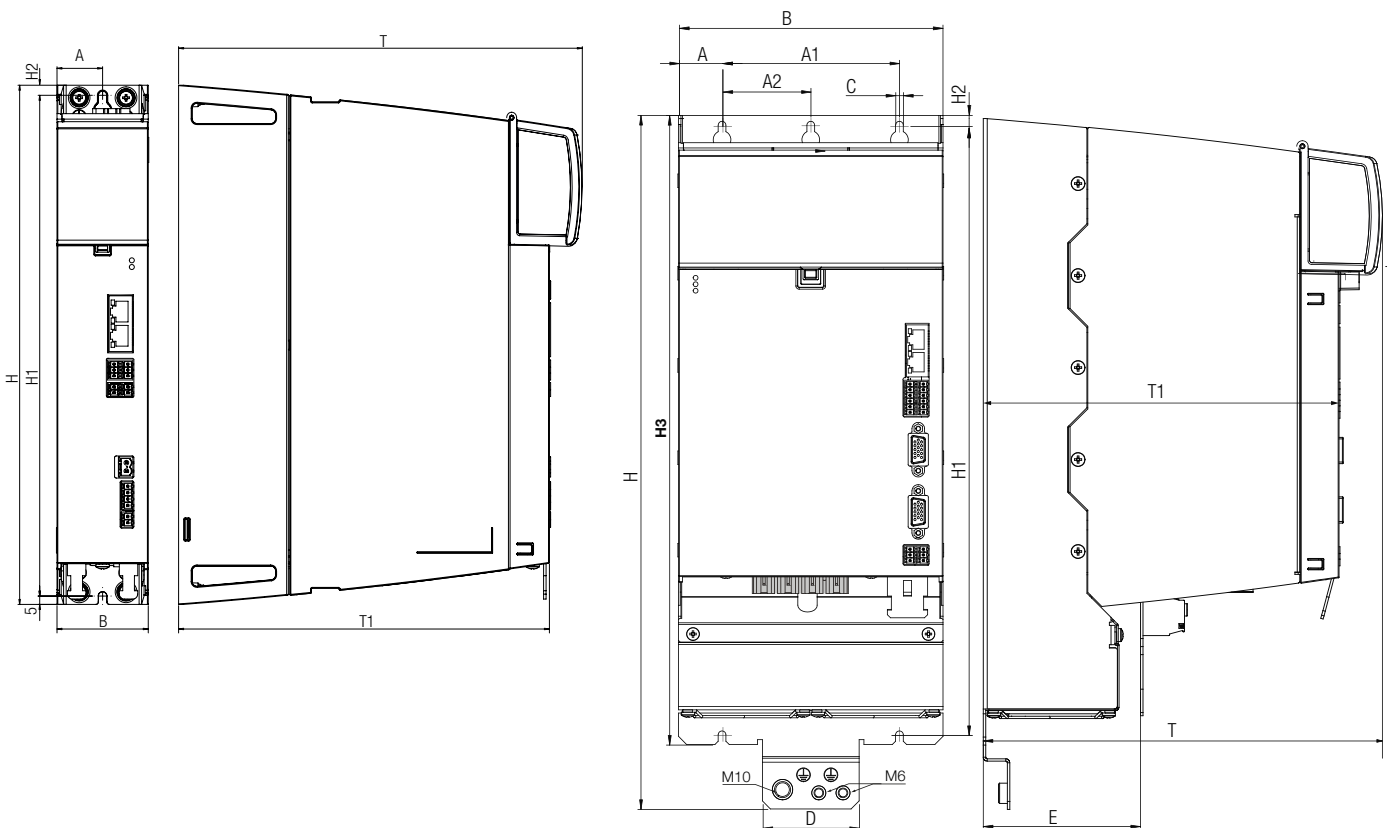

Figure 3.1 Dimensional sketches, KeDrive D3-DL 300 charging module

Figure 3.2 Dimensional sketches, KeDrive D3-DP 310 supply module (heat sink)

3.1.8 Dimensions, supply module (liquid cooling)

KeDrive D3-DP 310 , BG3	
Type	KeDrive D3-DP 310/C-30xx KeDrive D3-DP 310/C-55xx
Weight	
B (width)	164
H (height)	430
T (total depth)	251
T1	222
T2	75.2
H1	378
H2	6
H3	390
E	247.5
A	27
A1	110
A2	55
F	70
G	47
C	4.8
D	80
D1	35 (bore for pipe fitting)
S Female thread	3/8 inch (female thread)
Side clearance	Direct butt mounting
Screws	5 x M4

All dimensions in mm.

Table 3.4 Dimensional sketches, KeDrive D3-DP 310 supply module (liquid cooling)

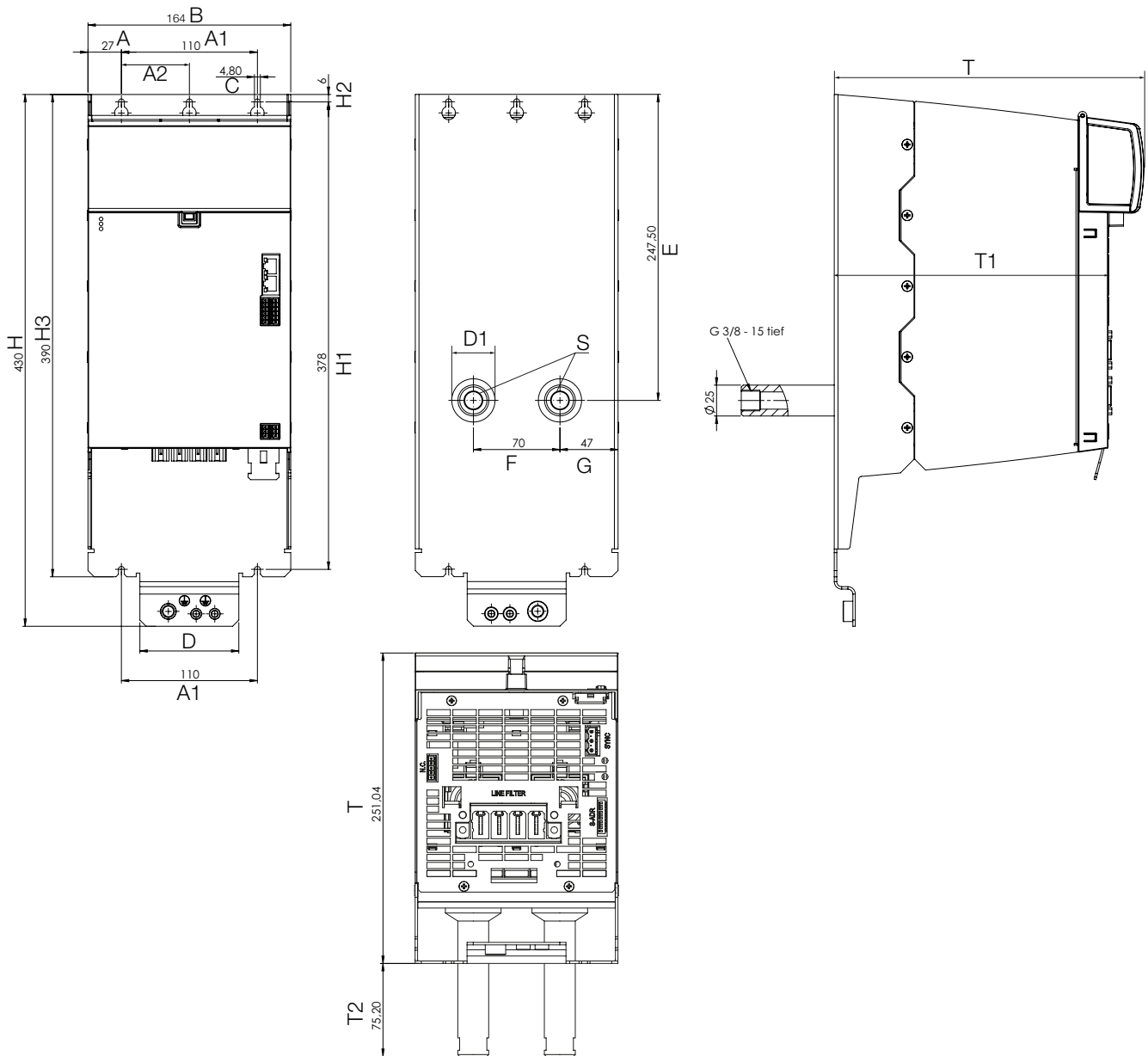

3

Figure 3.3 Dimensional sketches, KeDrive D3-DP 310 supply module, liquid cooling

3.2 Connector sets

Connector set for charging module D3-DL 300/A-xx

Figure	Order designation	Explanation
	<p>D3-XT 229/A</p>	<p>1 = X23A- (R01) - Relay output for control of main contactor (terminal) 2 = X01C Input/output 24 V DC 3 = X30A - Connection for braking resistor incl. thermal contact (via terminals) 4 = X20A - Digital outputs + relay output (R00) 5 = 2x EMC cable clamp 10-16 mm and 16-27 mm 6 = X27A - Temp. monitoring mains choke/ filter, temp. monitoring braking resistor 7 = X01A - Mains input (L1, L2, L3 / 3 x 400 V AC) - for DC link power supply to the axis controllers</p>

Connector set for supply module D3-DP 310/x-30

Figure (similar to illustration)	Order designation	Explanation
	<p>D3-XT 222/A</p>	<p>1 = Connector for power connection LC unit 2 = Connector for digital inputs 3 = Connector for safe digital inputs 4 = Connector for mains input for synchronisation 5 = Connector for filter (temp+FAN) 6 = Shield clamps 2 x 16-27 mm</p>

Connector set for supply module D3-DP 310/x-55

Figure (similar to illustration)	Order designation	Explanation
	D3-XT 225/A	<p>1 = Connector for power connection LC unit</p> <p>2 = Connector for digital inputs</p> <p>3 = Connector for safe inputs</p> <p>4 = Connector for filter (temp+FAN)</p> <p>5 = Connector for mains input for synchronisation</p> <p>6 = Shield clamps 2x 16-27 mm</p>

4 Axis controllers

4.1 System overview

Device	KeDrive D3-DA axis controller BG1+2	KeDrive D3-DA axis controller BG3+4
--------	--	--

Fig.



Operation Manual

1404.200B.x

1804.200B.x



NOTE:

The latest operation manuals and other documents are available in German, English and other languages and can be downloaded from our homepage

<https://www.keba.com/de/industrial-automation/service-support/downloads/doku-data-portal>

4.2 D3-DA 3xx - axis controllers

Comprehensive performance scaling

The drive system KeDrive D3 offers axis controllers as single-axis, double-axis and triple-axis controllers in a power range up to 250 A for optimal system design.

Cost-effective drive systems for 4 axes (3 + 1), 5 axes (3 + 2), 6 axes (3 + 3) or more can therefore be combined without problems and that not only for a specific sector, as the control technology meets the highest requirements even applications in the machine tool industry are possible. Due to the innovative usage of technology, the control performance also remains identical independent of the number of drive controller axes. Thanks to the development of a special drive ASIC, consistent performance from single-axis to triple-axis controllers is realised.

There are also no restrictions on the usage of different encoder technologies, as proven interfaces such as resolver, sine/cosine, HIPERFACE® or EnDAT are available along with the latest one-cable solutions to the servomotor.

Central supply

D3-DA 3xx axis controllers are supplied with power and auxiliary power via a central supply unit D3-DP 30x.

The number of axis controllers that can be arranged beside a supply unit is dependent on the power (power supply and auxiliary power supply) required for the application and must be taken into account during the project planning of the multi-axis system. A maximum of 8 axis controllers (corresponding to a maximum of 24 axes) can be operated on a supply unit.

With the aid of the expansion module, a second row can be established and in this way the number of axis controllers expanded.

Safety technology

The axis controller provides scalable integrated safety technology. In the standard model the functions STO (Safe Torque Off) and SBC (Safe Brake Control) are available. The expanded, optional "functional safety" forms, together with the central safety control FSM, a system for axis monitoring connected via EtherCAT. This can include safe and non-safe encoders and encoder combinations (HIPERFACE DSL®, SinCos, resolver, TTL and HTL) that are evaluated directly on the axis controller.

Field bus

The D3-DA 3xx axis controllers are designed for operation on the EtherCAT CoE field bus system. Bus cycle times of a minimum of 125 µs can be configured. Operation on alternative field bus systems such as Powerlink or PROFINet is also possible.

In operation, service and diagnostics access is by tunnelling via the central controller (EtherCAT EoE). For this purpose the controller must support the routing function for TCP/IP communication via EoE (Ethernet-over-EtherCAT). Digital inputs are available for axis-related functions, such as limit switch or reference mark evaluation.

4.2.1 Overview of the connections, D3-DA 3xx (BG1)

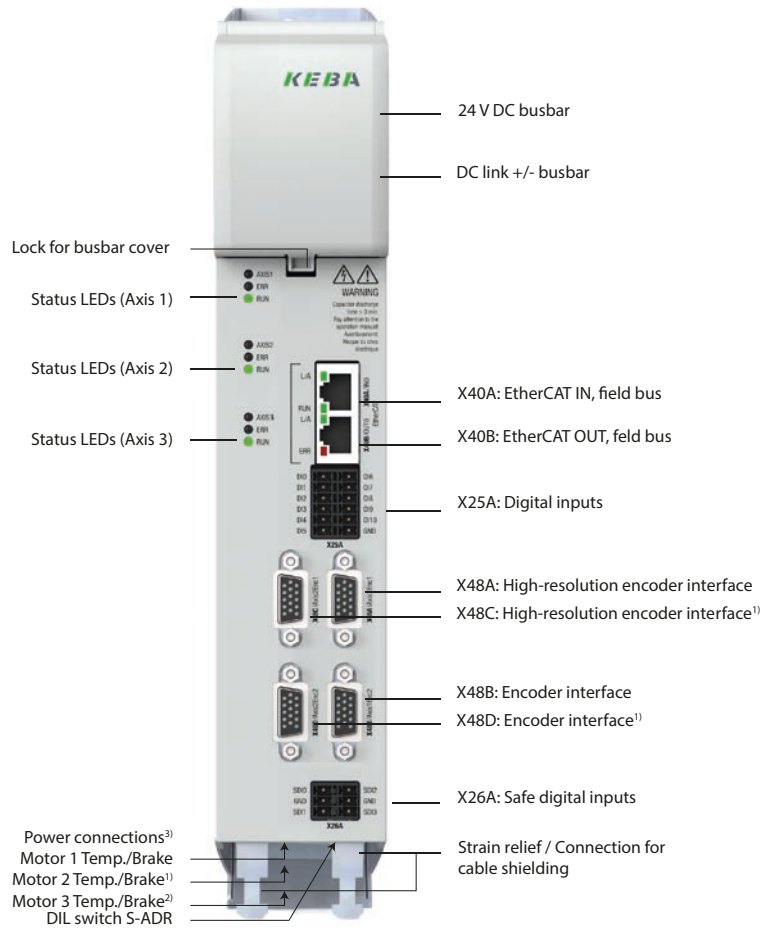

4

1) Only on KeDrive D3 double and triple-axis controllers.
 2) Only on KeDrive D3 triple-axis controllers.
 3) Arranged on underside of the D3-DA 3xx axis controller

Included in the scope of supply		For details see
Axis controller	D3-DA 310/x KeDrive D3 single-axis controller or D3-DA 320/x KeDrive D3 double-axis controller or D3-DA 330/x KeDrive D3 triple-axis controller	Chapter 4.2
Data cable set	For EtherCAT and cross-communication	Chapter 7.3.4
Busbar elements	For 24 V DC supply and DC link power supply	-
Documentation	Document set	Chapter 7.2
Optional (not included in the scope of supply)		
Connector set	For control and motor connections	Chapter 4.2.8

4.2.2 Overview of the connections, D3-DA 3xx (BG2)

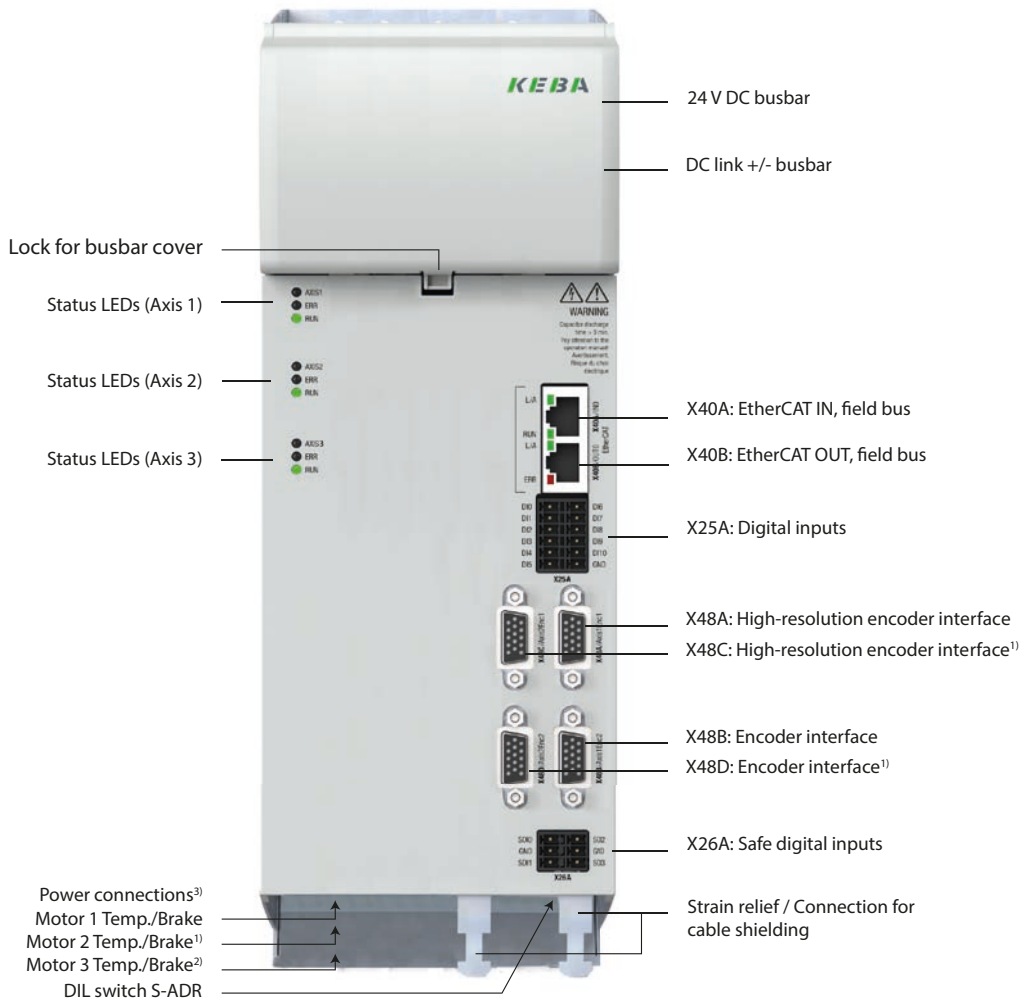

1) Only on KeDrive D3 double and triple-axis controllers.
 2) Only on KeDrive D3 triple-axis controllers.
 3) Arranged on underside of the D3-DA 3xx axis controller

Included in the scope of supply		For details see
Axis controller	D3-DA 310/x KeDrive D3 single-axis controller or D3-DA 320/x KeDrive D3 double-axis controller or D3-DA 330/x KeDrive D3 triple-axis controller	Chapter 4.2
Data cable set	For EtherCAT and cross-communication	Chapter 7.3.4
Busbar elements	For 24 V DC supply and DC link power supply	-
Documentation	Document set	Chapter 7.2
Optional (not included in the scope of supply)		
Connector set	For control and motor connections	Chapter 4.2.8

4.2.3 Overview of the connections, D3-DA 3xx (BG3)



4

1) Only on KeDrive D3 double-axis controllers.
 2) Arranged on the underside of the D3-DA 3xx axis controller

Scope of supply		For details see
Axis controller	D3-DA 310/x KeDrive D3 single-axis controller or D3-DA 320/x KeDrive D3 double-axis controller	Chapter 4.2
Data cable set	For EtherCAT and cross-communication	Chapter 7.3.4
Busbar elements	For 24 V DC supply and DC link power supply	-
Documentation	Document set	Chapter 7.2
Optional (not included in the scope of supply)		
Connector set	For control and motor connections	Chapter 4.2.8

4.2.4 Overview of the connections, D3-DA 3xx axis controller (BG4)

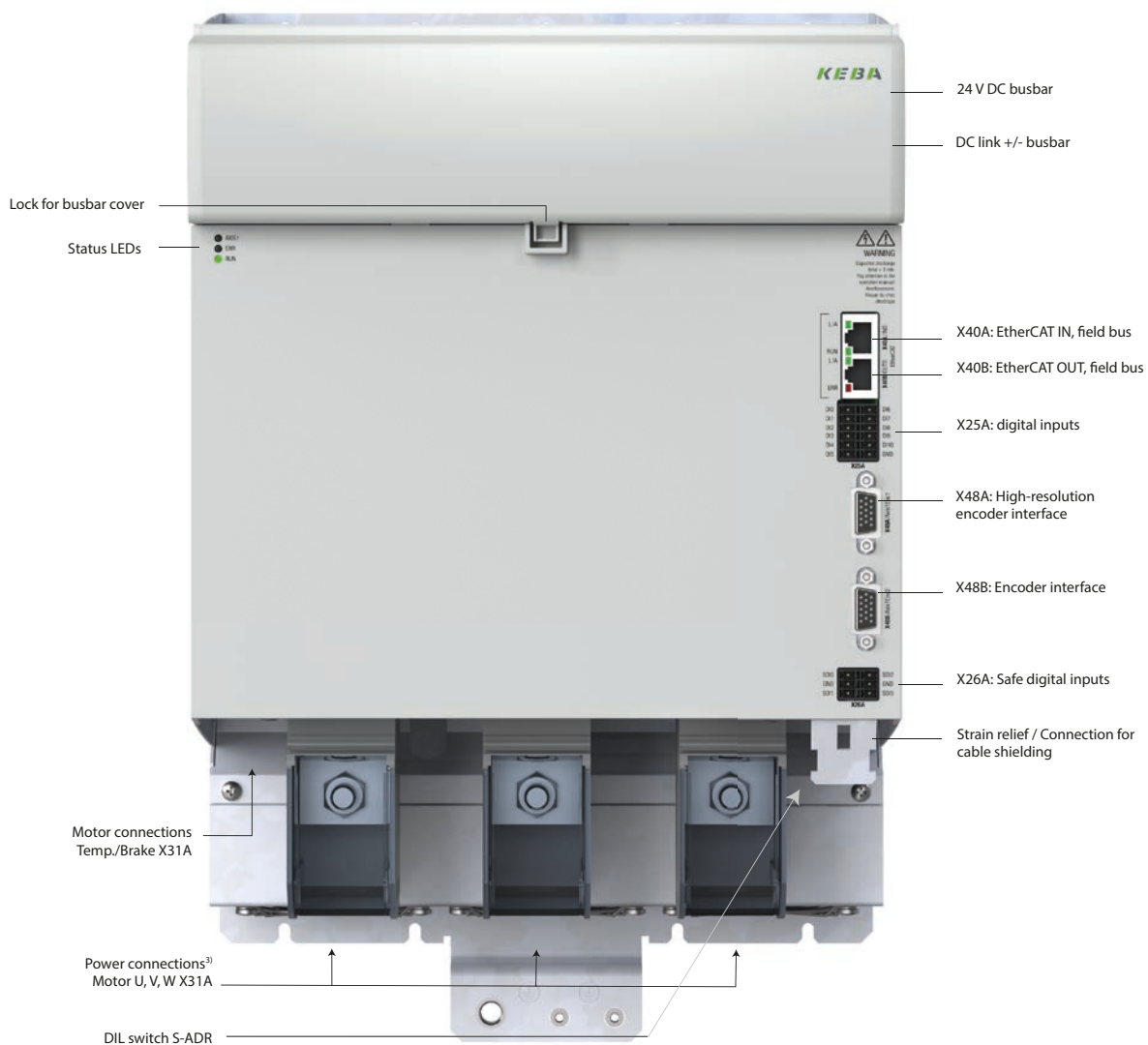

3) Arranged on the underside of the KeDrive D3-DA axis controller

Scope of supply		For details see
Axis controller	KeDrive D3 single axis D3-DA 310/x	Chapter 4.2
Data cable set	For EtherCAT and cross-communication	Chapter 7.3.4
Busbar elements	For 24 V DC supply and DC link power supply	-
Documentation	Document set	Chapter 7.2
Optional (not included in the scope of supply)		
Connector set	For control and motor connections	Chapter 4.2.8

4.2.5 Order code, D3-DA 3xx axis controller -

Name	D3 - DA 3 2 0 / A - 4 5 1 2 - 0 0 0 1 - 0 0 0 0
Module type	Axis module
Product line	
Number of axes	1: Single-axis 2: Double-axis module 3: Triple-axis module
Supply	0: DC voltage
Cooling	A: Heat sink B: Cooling plate (only BG1+BG2) C: Liquid cooling
Rated current	01: 1.5 A BG1 (1 + 2 + 3 axes) 03: 3 A BG1 (1 + 2 + 3 axes) 06: 6 A BG1 (1 + 2 + 3 axes) 12: 12 A BG1 (1 axis) BG2 (2 + 3 axes) 16: 16 A BG2 (only 2 axes) 18: 18 A BG1 (only 1 axis) 24: 24 A BG2 (1 axis) BG3 (2 axes) 32: 32 A BG2 (1 axis) BG3 (2 axes) 45: 45 A BG3 (only 1 + 2 axes) 80: 80 A BG3 (only 1 axis) A3: 130 A BG4* (only 1 axis) B1: 210 A BG4 (only 1 axis) **
Encoder interface	0: None 1: Multi-encoder and single encoder interface 2: Hiperface DSL® (one-cable solution) 3: Hiperface DSL® (one-cable solution)+ multi-encoder interface
Safety function	1: SDO (STO and SBC) 2: SDC (encoder version SinCos + HDSL®) 3: SDC (encoder version SinCos + EnDat2.2)* 4: SDC (encoder version Resolver + HDSL®) 5: SDC (encoder version Resolver + EnDat2.2)* 6: n. a. 7: SDC (encoder version SinCos + HDSL®) with firmware V3.0.0.8 8: SDC (encoder version Resolver + HDSL®) with firmware V3.0.0.8
Options	0: Not including protective coating, not including frequency limiting 1: Including protective coating, not including frequency limiting 2: Not including protective coating, including frequency limiting, output frequency < 600 Hz 3: Including protective coating, including frequency limiting, output frequency < 600 Hz
Hardware version	0: First version 1: New field bus controller
Model	00: Not including product documentation *** 01: Including product documentation (standard variant) 02: Including connector sets, not including product documentation *** 03: Including connector sets, including product documentation
Field bus	0: EtherCAT 1: Powerlink* 2: PROFINET
Reserved	

* Upon request, ** Rated current for liquid-cooled variant = 250 A, ***) Only contract customers

4.2.6 Power and function overview, D3-DA 3xx axis controller

Axis controller KeDrive D3		Single-axis controller	Double-axis controller	Triple-axis controller	
	Rated current ¹⁾	Overload current ²⁾			
Size (BG) 1	1.5 A /-	4.5 A	X	X	X
	3 A/-	9 A	X	X	X
	6 A/-	18 A	X	X	X
	12 A/-	36 A	X	-	-
	18 A/-	54 A	X	-	-
Size (BG) 2	12 A/-	36 A	-	X	X
	16 A/-	40 A	-	X	-
	24 A/-	67 A	X	-	-
	32 A/-	100 A	X	-	-
Size (BG) 3	24 A/-	72 A	-	X	-
	32 A/-	96 A	-	X	-
	45 A/-	135 A	X	X	-
	80 A / 80 A	160 A	X	-	-
Size (BG) 4	130 A /150 A	200 A/200 A	X	-	-
	210 A/ 250 A	250 A/315 A	X	-	-
Dimensions (air-cooled) H x W x D	Size (BG) 1	310 mm x 55 mm x 241 mm			
	Size (BG) 2	310 mm x 110 mm x 241 mm			
	Size (BG) 3	390 mm x 164 mm x 251 mm			
	Size (BG) 4	390 mm x 274 mm x 251 mm			
Multi-encoder interface (resolver, SinCos, SinCos + HIPERFACE®, EnDAT 2.1, EnDAT 2.2)		1	2	3	
Single encoder interface SinCos, TTL		1	2	1 (axis 1)	
Field bus		EtherCAT CoE (optional Powerlink, PROFINet)			
Standard inputs		9 standard inputs (1 ms) 3 touch probes (2x 2 µs, 1x 10 µs)			
Safety inputs		4 inputs (1 ms)			
Motor holding brake		Max. 24 VC, 2 A, (SBC as per SIL2)			
Safety functions		STO (SIL3, PLe, cat 4) + SBC (SIL3, PLe, cat 4)			
Safety technology option		Integrated safety control (SIL3, PLe, cat 4) Encoder version dependent on order code Safety functions supported and technical data See model description SDC			
Type of cooling		Air cooling (heat sink), cold plate or liquid cooling			
Mains filter		Ext. combined mains filter for supply unit			

1) For air / liquid cooling, 2) For information about overload see Chapter Table 4.6 ff

Table 4.5 KeDrive D3 axis controller overview



NOTE:

A maximum of 8 axis controllers can be attached to a supply unit. With the aid of the expansion module, a second row can be established and in this way the number of axis controllers expanded.

Technical data, D3-DA 3xx axis controller **BG1** / 1.5 to 3 A

KeDrive D3	Unit	D3-DA 310/ x-01	D3-DA 320/ x-01	D3-DA 330/ x-01	D3-DA 310/ x-03	D3-DA 320/ x-03	D3-DA330/ x-03
Single-axis controller size (BG) 1							
Number of axes		1	2	3	1	2	3
Rated current ¹⁾	A _{eff}	1 x 1.5	2 x 1.5	3 x 1.5	1 x 3.0	2 x 3.0	3 x 3.0
Overload current for 10 s ¹⁾	A _{eff}	1 x 3.0	2 x 3.0	3 x 3.0	1 x 6.0	2 x 6.0	3 x 6.0
Peak current for 500 ms ¹⁾	A _{eff}	1 x 4.5	2 x 4.5	3 x 4.5	1 x 9.0	2 x 9.0	3 x 9.0
Control section							
Control voltage	V DC	24 ± 20%					
Max. switch-on current at the 24 V power supply unit, per device/pulse duration	A	1.8 (at 24 V) and 2.2 (at 18 V) / 1 s					
Control voltage if a motor holding brake is used with cable length < 50 m	V DC	≥ 22.8 (24 V -5%)					
Power output, motor holding brake (max.)	W	48	2 x 48	3 x 48	48	2 x 48	3 x 48
DC link							
Capacitance in the DC link	µF	165					
Power section							
Permissible switching frequencies	kHz	2 / 4 / 8 / 12 / 16					
Rate of rise of voltage on the output with 10 m motor cable (10%-90%)	kV/µs	3...8					
Output frequency range @ 4 kHz	Hz	0 ... 400, up to max. 1600					
Power dissipation @ (400 V/ 4 kHz/ I _{rated}) in the interior	W	61	69	78	64	76	88
Power dissipation @ (400 V/ 4 kHz/ I _{rated}) via heat sink	W	12	24	26	24	48	72
Ambient conditions							
Ambient temperature/ max. temperature with derating	°C	5...40/ 50					
Current derating in the range 40 ... 50 °C	% per 1 °C	3.4					
Installation altitude	m	≤ 1000					
Installation altitude > 1000 m with derating		1%/ 100 m (up to max. 2000 m)					
Installation requirements, switch cabinet degree of protection		Built-in unit, only for mounting in a switch cabinet with min. IP4x degree of protection, if functional safety used (e.g. STO, SBC, etc.) with min. IP54 degree of protection					
<i>1) At 4 kHz, 400 V AC power feed via supply unit, for other currents see operation manual</i>							

Table 4.6 Tech. data, KeDrive D3 axis controller BG1

Technical data, D3-DA 3xx axis controller **BG1** / 6 to 18 A

KeDrive D3	Unit	D3-DA 310/x-06	D3-DA 320/x-06	D3-DA 330/x-06	D3-DA 310/x-12	D3-DA 310/x-18
Single-axis controller size (BG) 1						
Number of axes		1	2	3	1	1
Rated current ¹⁾	A _{eff}	1 x 6	2 x 6	3 x 6	1 x 12	1 x 18
Overload current for 10 s ¹⁾	A _{eff}	1 x 12	2 x 12	3 x 12	1 x 24 ²⁾	1 x 36 ²⁾
Peak current for 500 ms ¹⁾	A _{eff}	1 x 18	2 x 18	3 x 18	1 x 36	1 x 54
Control section						
Control voltage	V DC	24 ± 20%				
Max. switch-on current at the 24 V power supply unit, per device/pulse duration	A	1.8 (at 24 V) and 2.2 (at 18 V) / 1 s				
Control voltage if a motor holding brake is used with cable length < 50 m	VDC	≥22.8 V (24 V-5%)				
Power output, motor holding brake (max.)	W	48	2x48	3x48	48	48
DC link						
Capacitance in the DC link	μF	165			275	
Power section						
Permissible switching frequencies	kHz	2 / 4 / 8 / 12 / 16				
Rate of rise of voltage on the output with 10 m motor cable (10%-90%)	kV/μs	3...8				
Output frequency range @ 4 kHz	Hz	0 ... 400, up to max. 1600				
Power dissipation @ (400 V/ 4 kHz/ I _{rated}) in the interior	W	68	84	100	95	102
Power dissipation @ (400 V/ 4 kHz/ I _{rated}) via heat sink	W	40	80	120	88	120
Ambient conditions						
Ambient temperature/ max. temperature with derating	°C	5...40/ 50			5...40/ 50	
Current derating in the range 40 ... 50 °C	%/ °C	3.4			1.6	
Installation altitude	m	≤ 1000				
Installation altitude > 1000 m with derating		1%/100 m (up to max. 2000 m)				
Installation requirements, switch cabinet degree of protection		Built-in unit, only for mounting in a switch cabinet with min. IP4x degree of protection, if functional safety used (e.g. STO, SBC, etc.) with min. IP54 degree of protection				
1) @ 4 kHz, 400 VAC power feed via supply unit, for other currents see operation manual 2) Overcurrent for 2 s						

Technical data, D3-DA 3xx axis controller **BG2** / 12 to 32 A

KeDrive D3	Unit	D3-DA 320/x-12	D3-DA 330/x-12	D3-DA 320/x-16	D3-DA 310/x-24	D3-DA 310/x-32
Single-axis controller size (BG) 2						
Number of axes		2	3	2	1	1
Rated current ¹⁾	A _{eff}	2 x 12	3 x 12	2 x 16	1 x 24	1 x 32
Overload current for 10 s ¹⁾	A _{eff}	2 x 24	3 x 24	2 x 32 ²⁾	1 x 48	1 x 64 ³⁾
Peak current for 500 ms ¹⁾	A _{eff}	2 x 36	3 x 36	2 x 40	1 x 67	1 x 100
Control section						
Control voltage	V DC	24 ± 20%				
Max. switch-on current at the 24 V power supply unit, per device/pulse duration	A	1.8 (at 24 V) and 2.2 (at 18 V) / 1 s				
Control voltage if a motor holding brake is used with cable length < 50 m	VDC	≥22.8 V (24 V-5%)				
Power output, motor holding brake	W	2x48	3x48	2x48	48	48
DC link						
Capacitance in the DC link	µF	405			675	
Power section						
Permissible switching frequencies	kHz	2 / 4 / 8 / 12 / 16				
Rate of rise of voltage on the output with 10 m motor cable (10%-90%)	kV/µs	3...8				
Output frequency range @ 4 kHz	Hz	0 ... 400, up to max. 1600				
Power dissipation @ (400 V/ 4 kHz/ I _{rated}) in the interior	W	118	141	129	103	112
Power dissipation @ (400 V/ 4 kHz/ I _{rated}) via heat sink	W	175	262	233	176	240
Ambient conditions						
Ambient temperature/ max. temperature with derating	°C	5...40/ 50				
Current derating in the range 40 ... 50 °C	%/ °C	2.0		2.6	2.3	3
Installation altitude	m	≤ 1000				
Installation altitude > 1000 m with derating		1%/ 100 m (up to max. 2000 m)				
Installation requirements, switch cabinet degree of protection		Built-in unit, only for mounting in a switch cabinet with min. IP4x degree of protection, if functional safety used (e.g. STO, SBC, etc.) with min. IP54 degree of protection				
1) @ 4 kHz, 400 VAC power feed via supply unit, for other currents see operation manual 2) Overcurrent for 2 s 3) Overcurrent for 1.5 s						

D3-DA 3xx axis controller **BG3** / 24 to 80 A

KeDrive D3	Unit	D3-DA 320/x-24xx	D3-DA 320/x-32xx	D3-DA 310/x-45xx	D3-DA 320/x-45xx	D3-DA 310/x-80xx
Single-axis controller size (BG) 3						
Number of axes		2	2	1	2	1
Rated current ¹⁾	A _{eff}	2 x 24	2 x 32	45	2 x 45	80
Overload current for 10 s ¹⁾	A _{eff}	2 x 48	2 x 64	90	2 x 90	160
Peak current for 300 ms ¹⁾	A _{eff}	2 x 72	2 x 96	135	2 x 135	240 (250 ms)
Control section						
Control voltage	V DC	24 ± 20%				
Max. switch-on current at the 24 V power supply unit, per device/pulse duration	A	1.8 (at 24 V) and 2.2 (at 18 V) / 1 s				
Control voltage if a motor holding brake is used with cable length < 50 m	V DC	≥ 22.8 (24 V -5%)				
Power consumption, typical (not including encoder)	W	25		20	25	20
Power output, motor holding brake	W	2 x 48 max.	2 x 48 max.	48 max.	2 x 48 max.	48 max.
DC link (DC input)						
Capacitance in the DC link (axis controller)	μF	1800	1800	1800	1800	1800
Power section (motor output)						
Permissible switching frequencies	kHz	2 / 4 / 8 / 12 / 16				
Rate of rise of voltage on the output with 10 m motor cable (10%-90%)	kV / μs	3 ... 8 (typical)				
Output frequency range @ 4 kHz	Hz	0 ... 400, up to max. 1600				
Power dissipation @ (400 V/ 4 kHz/ I _{rated}) in the interior, air-cooled	W	144	163	137	179	168
Power dissipation @ (400 V/ 4 kHz/ I _{rated}) in the interior, liquid-cooled	W	65	84	58	100	89
Power dissipation @ (400 V/ 4 kHz/ I _{rated}) via heat sink ²⁾	W	565	714	493	989	879
Ambient conditions						
Ambient temperature/ max. temperature with derating	°C	5 ... 40/ to 55 with derating				
Current derating in the range 40 ... 55 °C	%/ °C	Reduction of the output power by 4.3%/ °C				
Installation altitude	m	≤ 1000				
Installation altitude > 1000 m with derating		Reduction of the output power by 1%/100 m (up to max. 3000 m)				
Installation requirements, switch cabinet degree of protection		"Built-in unit, only for mounting in a switch cabinet with min. IP4x degree of protection, if functional safety used (e.g. STO, SBC, etc.) with min. IP54 degree of protection"				
1) At 4 kHz, 400 V AC power feed via supply unit, for other currents see operation manual						

**NOTE:**

Until the type test is completed, all technical data are only calculated values and not assured characteristics.

D3-DA 3xx axis controller **BG4** / 130 to 250 A

KeDrive D3	Unit	D3-DA 310/A-A3xx	D3-DA 310/C-A3xx	D3-DA 310/A-B1xx	D3-DA 310/C-B1xx
Single-axis controller size (BG 4)					
Number of axes		1	1	1	1
Rated current ¹⁾	A _{eff}	130	150	210	250
Overload current for 10 s ¹⁾	A _{eff}	200		250	315
Peak current for 200 ms ¹⁾	A _{eff}	280		315	395
Control section					
Control voltage	V DC	24 ± 20%			
Max. switch-on current at the 24 V power supply unit, per device/pulse duration	A	1.8 (at 24 V) and 2.2 (at 18 V) / 1 s			
Control voltage if a motor holding brake is used with cable length < 50 m	V DC	≥ 22.8 (24 V -5%)			
Power consumption, typical (not including encoder)	W	20		20	
Power output, motor holding brake	W	48 max.		48 max	
DC link (DC input)					
Capacitance in the DC link (axis controller)	μF	2700		3600	
Power section (motor output)					
Permissible switching frequencies	kHz	2 / 4 / 8 / 12 / 16			
Rate of rise of voltage on the output with 10 m motor cable (10%-90%)	kV / μs	3 ...8			
Output frequency range @ 4 kHz	Hz	0 ... 400 up to max. 1600			
Power dissipation @ (400 V/ 4 kHz/ I _{rated}) in the interior, air-cooled	W	248		306	
Power dissipation @ (400 V/ 4 kHz/ I _{rated}) in the interior, liquid-cooled	W	130		217	
Power dissipation @ (400 V/ 4 kHz/ P _{rated}) via heat sink ²⁾	W	1434		2445	
Ambient conditions					
Ambient temperature/ max. temperature with derating	°C	5...40/ 55			
Current derating in the range 40 ... 55 °C	%/ °C	Reduction of the output power by 4.3%/ °C			
Installation altitude	m	≤ 1000			
Installation altitude > 1000 m with derating		Reduction of the output power by 1%/100 m (up to max. 3000 m)			
Installation requirements, switch cabinet degree of protection		"Built-in unit, only for mounting in a switch cabinet with min. IP4x degree of protection, if functional safety used (e.g. STO, SBC, etc.) with min. IP54 degree of protection"			
¹⁾ At 4 kHz, 400 V AC power feed via supply unit, for other currents see operation manual					

4

**NOTE:**

Until the type test is completed, all technical data are only calculated values and not assured characteristics.

4.2.7 Installation and dimensions, D3-DA 3xx axis controller

D3-DA 3xx axis controller **BG1**

KeDrive D3	Unit	BG1	
Cooling method		Heat sink (air-cooled)	Cold plate
Mounting method		Vertical mounting with unhindered air flow	Vertical mounting on thermally conductive film
Weight	kg	2.7	2.3
Side clearance, butt mounting clearance	mm	0	0
B (width)	mm	55	
H (height)	mm	310	
T / T1 (depth)	mm	241 / 222 ¹⁾	189 / 170 ¹⁾
H1	mm	299	
H2	mm	6	
A	mm	27.5	
A1	mm	-	
C / fitting	mm	5	

1) Without terminals and connectors

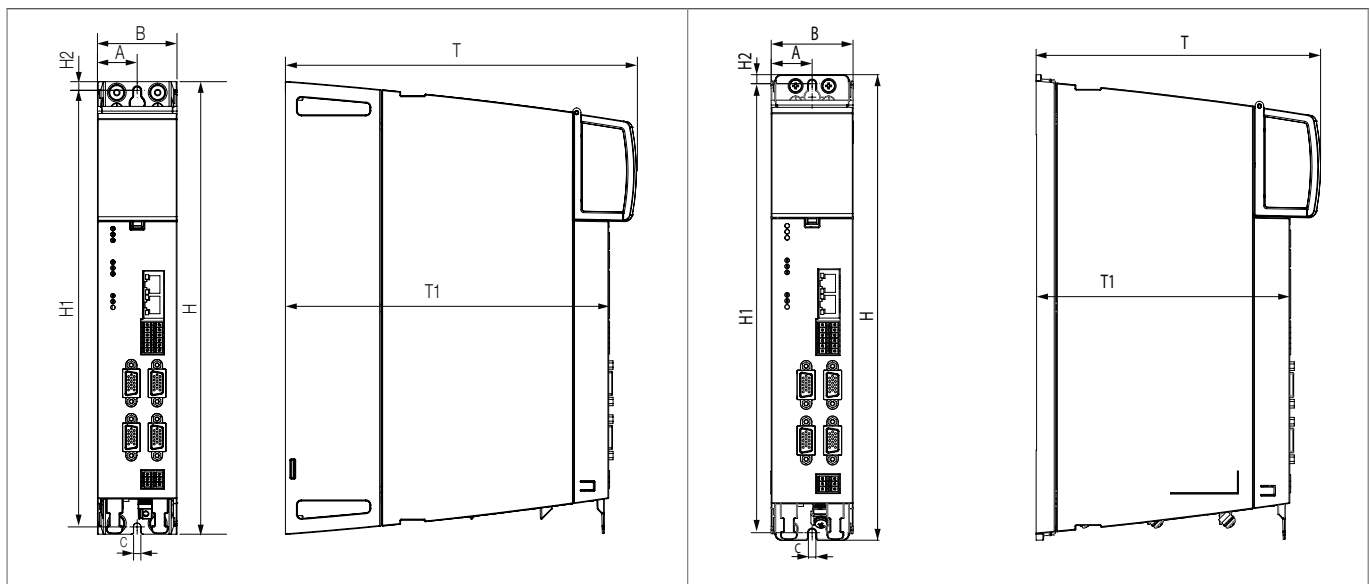

Dimensional sketch with heat sink (air-cooled) (BG1)

Dimensional sketch, cold plate (BG1)

D3-DA 3xx axis controller **BG2**

KeDrive D3	Unit	BG2	
Cooling method		Heat sink (air-cooled)	Cold plate
Mounting method		Vertical mounting with unhindered air flow	Vertical mounting on thermally conductive film
Weight	kg	4.5	3.7
Side clearance, butt mounting clearance	mm	0	0
B (width)	mm	110	
H (height)	mm	310	
T / T1 (depth)	mm	241 / 222 ¹⁾	189 / 170 ¹⁾
H1	mm	299	
H2	mm	6	
A	mm	27.5	
A1	mm	55	
C / fitting	mm	5 / 4 xM4	

1) Without terminals and connectors

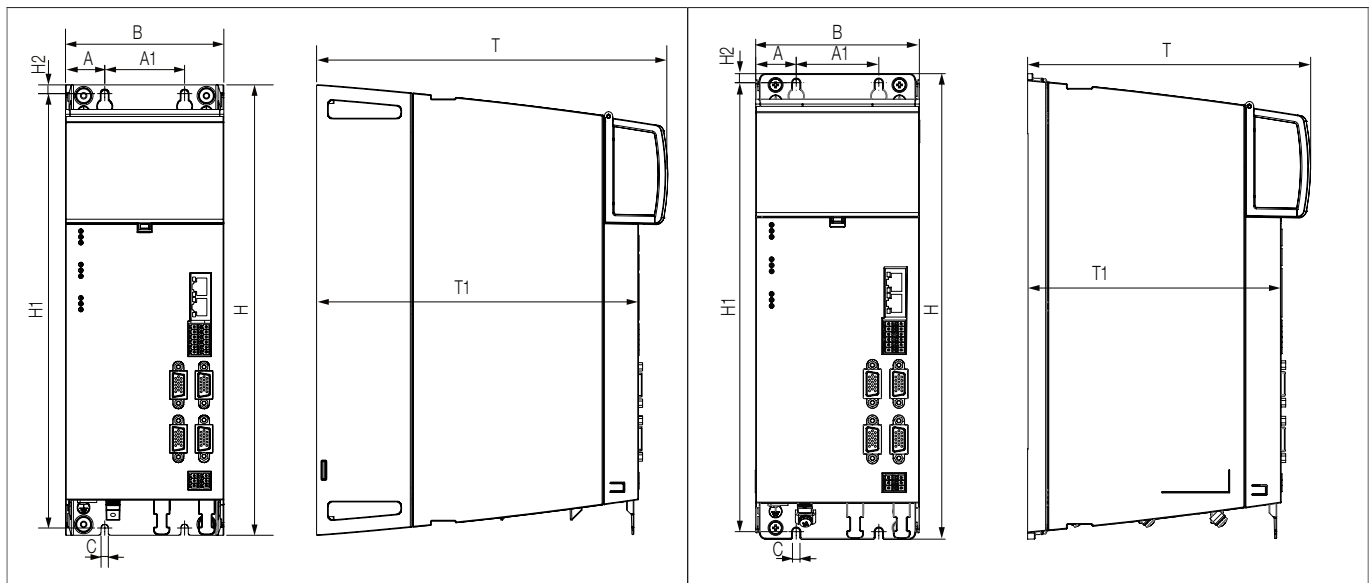

Dimensional sketch with heat sink (air-cooled) (BG2)

Dimensional sketch, cold plate (BG2)



NOTE:

You will find more detailed information about mounting in the Operation Manual KeDrive D3 Axis Controller (ID. no.: 1404.200B.x-xx).

D3-DA 3xx axis controller **BG3**

KeDrive D3	Unit	BG3	
Cooling method		Heat sink (air-cooled)	Liquid-cooled
Mounting method		Vertical mounting with unhindered air flow	Vertical mounting, coolant connection from rear
Weight	kg	Approx. 13	Approx. 20
B (width)	mm	164	
H (height)	mm	430	
T / T1 (depth)	mm	251 / 222 ¹⁾	252 / 75.2
H1 / H2	mm	378 / 6	390 / 6
H3	mm	390	378
A	mm	27	
A1 / A2	mm	110 / -	110 / 55
C	mm	4.8	
D / D1	mm	80 / -	80 / 35 (bore for pipe fitting)
E / F	mm	98 / -	247 / 70
G	mm	-	47
Screws		4 x M4	5 x M4

1) Without terminals and connectors

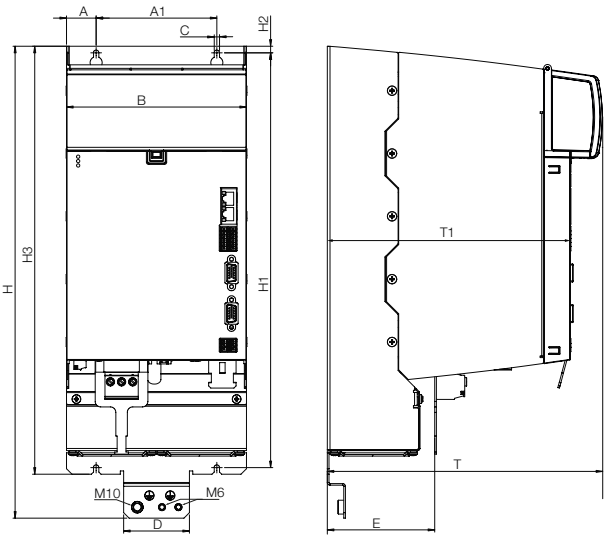

Dimensional drawing, KeDrive D3 axis controller BG3, air-cooled

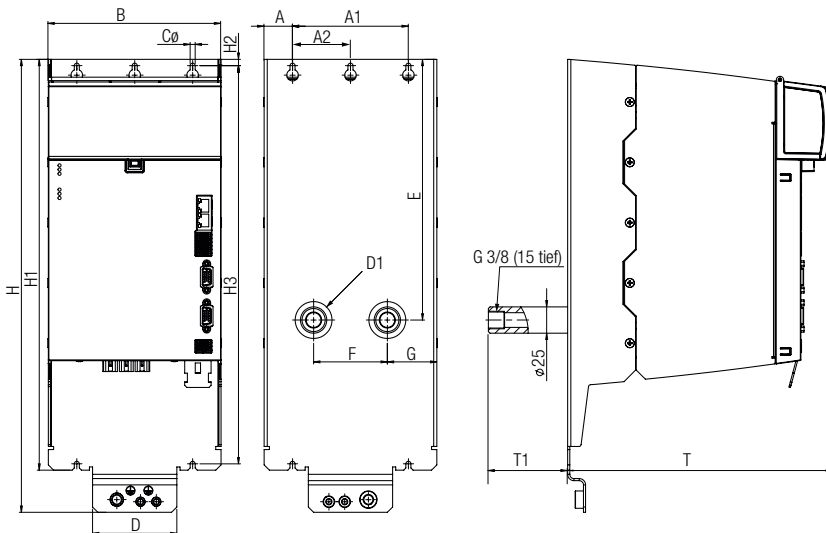

Dimensional drawing, D3-DA 3xx axis controller BG3, liquid-cooled

4

Table 4.7 Dimensional drawings



NOTE:

You will find more detailed information about mounting in the Operation Manual KeDrive D3 Axis Controller (ID. no.: 1804.200B.x-xx).

D3-DA 3xx axis controller **BG4**

KeDrive D3	Unit	BG4	
Cooling method		Heat sink (air-cooled)	Liquid-cooled
Mounting method		Vertical mounting with unhindered air flow	Vertical mounting, coolant connection from rear
Weight approx.	kg	Approx. 20	Approx. 20
H (height)	mm	430	
B (width)	mm	274	
T / T1 (depth)	mm	251 / 222 ¹⁾	251 / 75.2
H1 / H2	mm	378 / 6	390 / 6
H3	mm	390	378
A	mm	27	
A1 / A2	mm	220 / -	220 / 110
C	mm	4.8	
D / D1	mm	80 / -	80 / 35 (bore for pipe fitting)
E / F	mm	98 / -	247 / 70
G	mm	-	102
Screws		4 x M4	9 x M4.
1) Without terminals and connectors			

Table 4.8 Dimensions, KeDrive D3-DA axis controller BG4

Dimensional drawing, D3-DA 3xx axis controller BG4 air-cooled

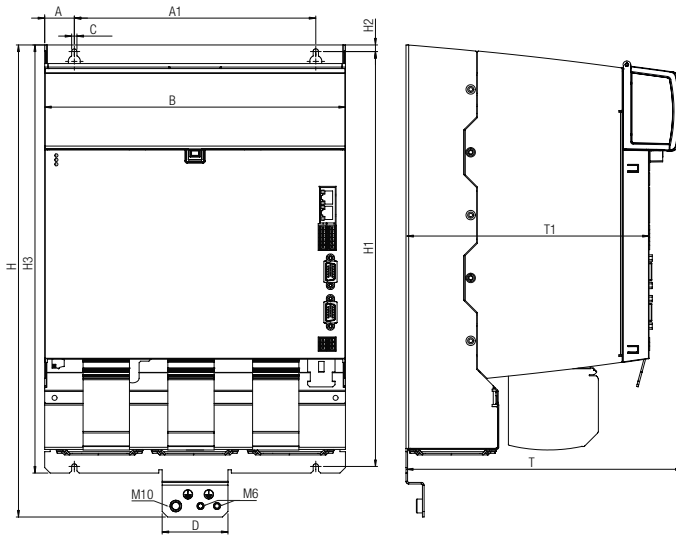

Dimensional drawing, D3-DA 3xx axis controller BG4, liquid-cooled

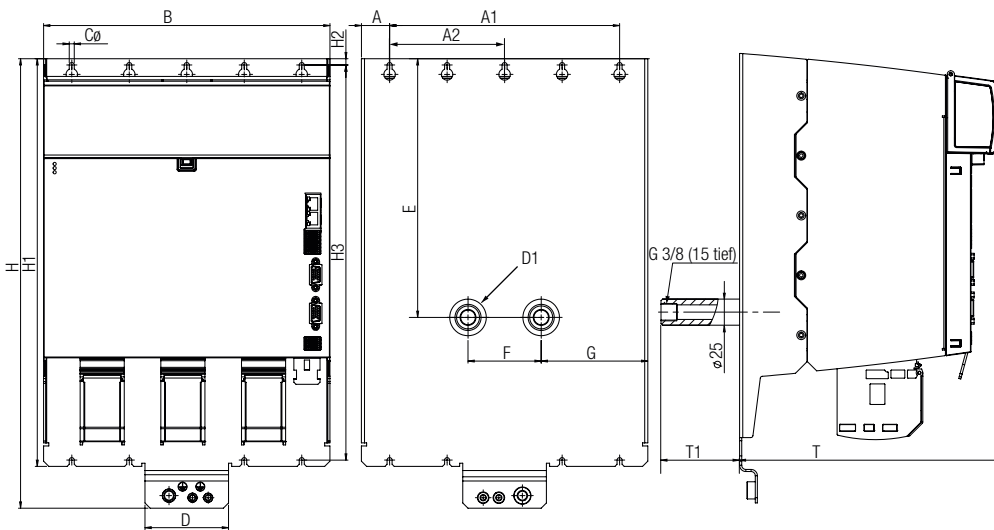

4

Figure 4.4 Dimensional drawings, KeDrive D3-DA BG4



NOTE:

You will find more detailed information about mounting in the Operation Manual KeDrive D3 Axis Controller (ID. no.: 1804.200B.x-xx).

4.2.8 Connector sets, D3-DA 3xx axis controller

The following connector sets are not included in the scope of supply and must be ordered in addition if required.

D3-DA 3xx axis controller BG1+2

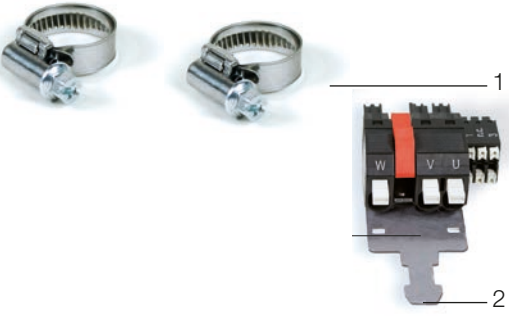
Figure	Order designation	Explanation
	<p>D3-XT 231/A 1 connector set per axis</p>	<p>1 = Cable clamps 2 = X31x - Motor power connection (with integrated connections for motor brake and motor temperature monitoring)</p>

D3-DA 3xx axis controller BG3

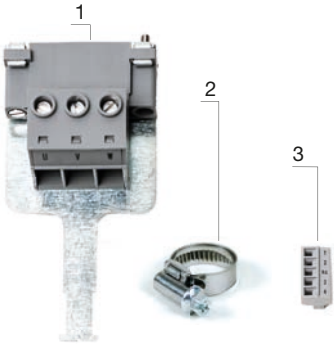
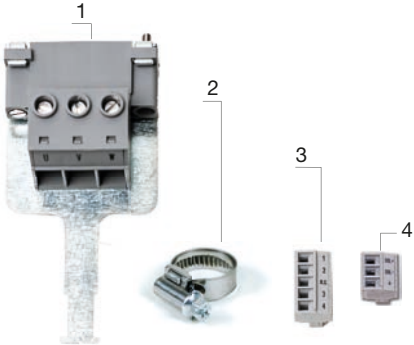
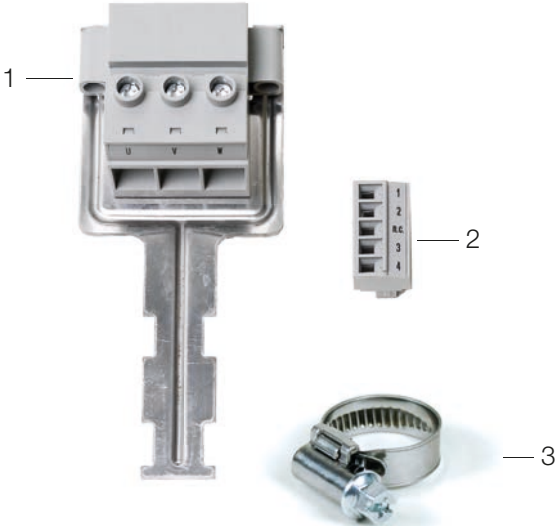

Figure	Order designation	Explanation
	<p>D3-XT 232/A for axis controllers: D3-DA 320/x-24 D3-DA 320/x-32 D3-DA 3x0/x-45 One connector set per axis</p>	<p>1 = Motor power connection 2 = Cable clamp 3 = X31A/X31B - Inputs (temp./brake)</p>
	<p>D3-XT 232/B for standard axis controllers: D3-DA 320/x-24 D3-DA 320/x-32 D3-DA 3x0/x-45 for axis controllers with HDSL: D3-DA 320/x-242(3)x D3-DA 320/x-322(3)x D3-DA 3x0/x-452(3)x One connector set per axis</p>	<p>1 = Motor power connection 2 = Cable clamp 3 = X31A/X31B - Inputs (temp./brake) 4 = HDSL terminals</p>

Figure	Order designation	Explanation
	<p>D3-XT 233/A for axis controllers: D3-DA 310.xx80</p>	<p>1 = Motor power connection 2 = X31A/X31B - Inputs (temp./brake) 3 = Cable clamp</p>

4

D3-DA 3xx axis controller BG4

Figure	Order designation	Explanation
	<p>D3-XT 23A/A for axis controllers: D3-DA 310/x-A3 D3-DA 310/x-B1</p>	<p>2 = X31A/X31B - Inputs (temp./brake)</p>

All D3-DA 3xx axis controllers

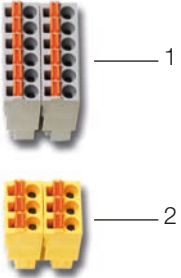
Figure	Order designation	Explanation
 <p>The figure shows two terminal blocks. The top one is grey with two columns of terminals, labeled '1'. The bottom one is yellow with two columns of terminals, labeled '2'.</p>	D3-XT 230/A for axis controllers: D3-DA 3x0/x-xx	1 = X25A - Digital inputs (programmable) 2 = X26A - Safe digital inputs

5 Controlled Energy storage system KeDrive D3

5.1 System overview

Device	KeDrive D3-EM energy manager	KeDrive D3-ES energy storage
--------	---------------------------------	---------------------------------

Fig.



Operation Manual

1804.209B.x



NOTE:

The latest operation manuals and other documents are available in German, English and other languages and can be downloaded from our homepage

<https://www.keba.com/de/industrial-automation/service-support/downloads/doku-data-portal>

5.1.1 Introduction

The KeDrive D3 drive system can be expanded with a controlled energy storage system. Essentially, the system consists of an energy manager and the energy storage.

Energy storage systems are used in a variety of applications. Whether for the storage of energy generated regeneratively in the drive system or for buffering and the provision of energy in peak load situations.

The energy manager KeDrive D3-EM, as a dynamically regulated step-down converter, makes use of a large DC link voltage range. In this way the system can store and deliver more energy compared to storage modules of the same capacity directly integrated into the DC link.

The energy storage system can be combined with both passive and active supply units. The requirements specify the selection of the supply.

- Regulated DC link voltage for clearly international drive design
- Independent of worldwide mains voltages
- Optimised energy storage in the DC link
- Reduction of mains distortion (THD) and reactive power caused by passive mains rectification
- Saving in mains connection costs due to limitation of the peak load consumption from the supply system
- Controlled energy storage for dynamic application
- Take advantage of KEBA expertise from research and applications for your bespoke "smart DC system" with the KEBA energy storage system.

5.1.2 Overview of the connections, KeDrive D3-EM energy manager

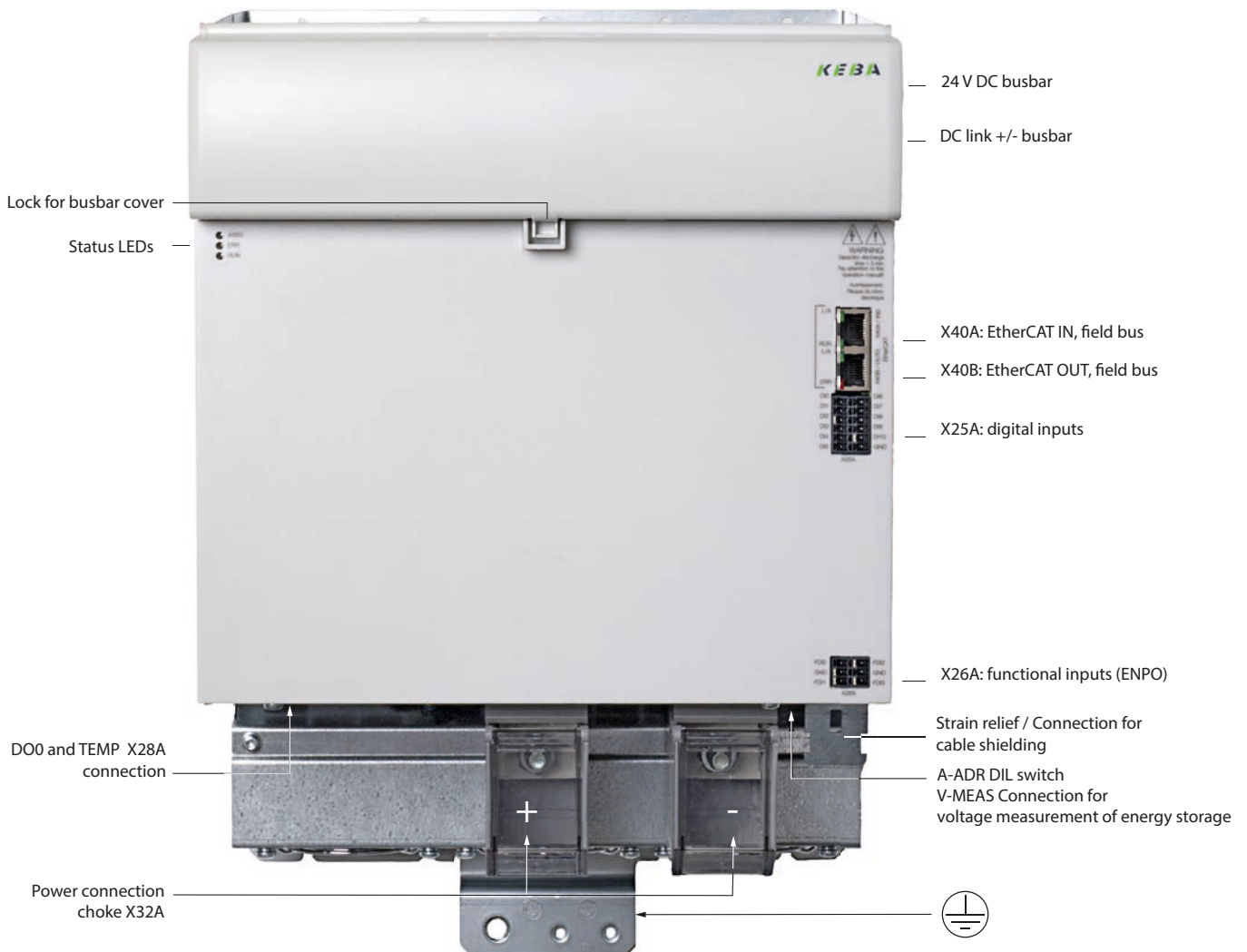

5

**NOTE:**

You will find descriptions and specifications for the above stated connections in the Operation Manual KeDrive D3 Energy Storage System (ID no.: 1804.209B.x-xx).

Included in the scope of supply		For details see
Energy manager	KeDrive D3-EM	Chapter 5.1.6
Busbar elements	Busbar elements for DC link connection and 24 V control supply (in the separate bag of accessories)	-
Documentation	Document set	Chapter 7.2
Optional (not included in the scope of supply)		
Connector set	D3-XT 227/A, D3-XT 230/A, D3-XT 23A/A	Chapter 5.1.10
Choke module	D3-EL 120/A-0100-00	Chapter 5.1.11

5.1.3 Overview of the connections, KeDrive D3-ES energy storage

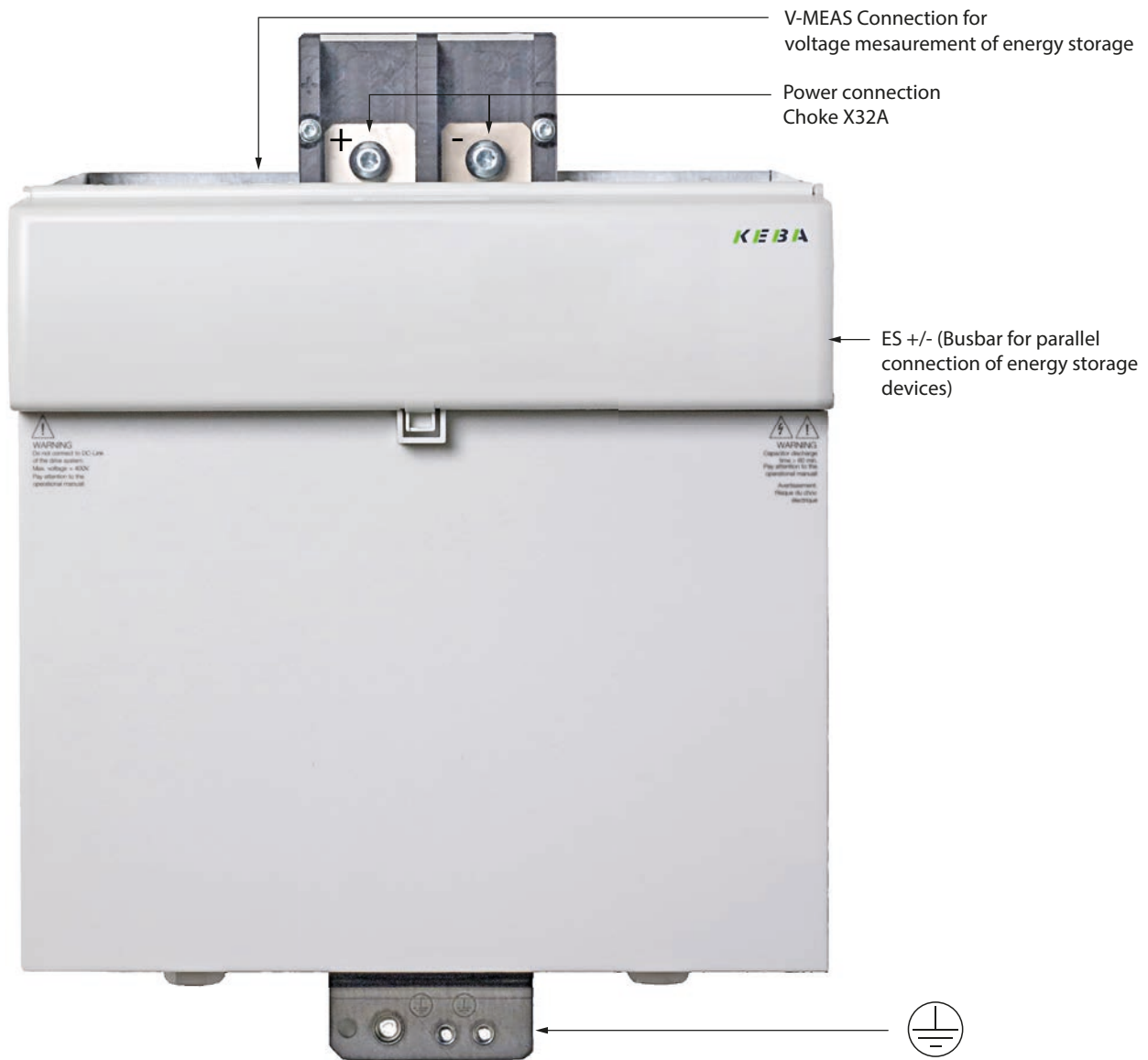
**NOTE:**

You will find descriptions and specifications for the above stated connections in the Operation Manual KeDrive D3 Energy Storage System (ID no.: 1804.209B.x-xx).

Included in the scope of supply		For details see
Energy storage	KeDrive D3-ES	Chapter 5.1.7
Busbar elements	Busbar elements for ES +/- connection (in the separate bag of accessories)	-
Documentation	Document set	Chapter 7.2
Optional (not included in the scope of supply)		
Connector set	D3-XT 227/A	Chapter 5.1.10

5.1.4 Order code, KeDrive D3-EM energy manager

D3 - EM 3 0 0 / A - B 1 0 0 - 0 0 0 0 - 0 0 0 0	
Module type	Energy manager
Product line	
Reserved	
Supply	0: DC voltage
Cooling	A: Heat sink C: Liquid cooling
Rated current	B1: 210 A BG4**
Reserved	
Safety function	0: None
Options	0: Not including protective coating 1: Including protective coating
Version	0:
Model	00: Not incl. product documentation 01: Incl. product documentation (standard variant) 02: Incl. connector sets, not incl. product documentation 03: Incl. connector sets, incl. product documentation
Field bus	0: EtherCAT 1: Powerlink* 2: PROFINET*
Reserved	

* Upon request, ** Rated current for liquid-cooled variant: 250 A

5

5.1.5 Order code, KeDrive D3-ES energy storage

D3 - ES 3 0 0 / A - A 1 0 0 - 0 0 0 0 - 0 0 0 0	
Module type	Energy storage
Product line	
Reserved	
Supply	0: Energy manager
Cooling	A: Heat sink
Capacitance	A1: 110 mF
Reserved	
Reserved	
Options	0: Not including protective coating 1: Including protective coating
Version	0:
Model	00: Not incl. product documentation 01: Incl. product documentation (standard variant) 02: Incl. connector sets, not incl. product documentation 03: Incl. connector sets, incl. product documentation
Reserved	
Reserved	

5.1.6 Technical data, KeDrive D3-EM energy manager



Note:

Until the type test is completed, all technical data are only calculated values and not assured characteristics!

Type	Unit	D3-EM 300/A-B1xx (BG4 ¹⁾)	D3-EM 300/C-B1xx (BG4 ¹⁾)
Energy manager			
Rated current ²⁾	A _{eff}	1 x 210	1 x 250
Maximum current for 10 s ²⁾	A _{eff}	1 x 250	1 x 315
Maximum current (for xxx ms) ²⁾	A _{eff}	1 x 315 (200 ms)	1 x 395 (200 ms)
Control section			
Control voltage	V DC	24 ± 20%	
Max. switch-on current at the 24 V power supply unit, per device	A	1.8 A at 24 V / 1 s and 2.2 at 18 V / 1 s	
Control voltage for relay output D00 with cable length < 50 m	V DC	≥ 22.8 (24 V -5%)	
Power consumption, typical	W	48	48
Maximum power, relay output D00	W	48 max	48 max
DC link (DC input)			
Capacitance in the DC link	µF	3600	3600
Power section			
Permissible switching frequency	kHz	4	
Rate of rise of voltage on the output	kV / µs	3 ...8 (typical)	
Ambient temperature	°C	5...40, up to 55 with derating	
Power dissipation @ (400 V/ 4 kHz/ I _{rated}) in the interior	W	xx	xx
Power dissipation @ (400 V/ 4 kHz/ P _{rated}) via heat sink	W	xx	xx
1) Upon request, 2) At 4 kHz, 400 V AC power feed via supply unit, for further current figures see following pages, xx not yet available at the time of going to press.			

Table 5.9 Technical data, KeDrive D3-EM BG4

Power section current data, 210 A to 250 A energy manager (BG4)

	U _{Mains}	F _S	Unit	D3-EM 300/A-B1xx (BG4 ¹⁾)	D3-EM 300/C-B1xx (BG4 ¹⁾)
Rated current	400 V	4 kHz	A	210	250
Overload current for 10 s			A	250	315
Maximum current for 500 ms			A	315	395
Maximum current for 10 ms			A	675	800
Rated current	480 V	4 kHz	A	xx	xx
Overload current for 10 s			A	xx	xx
Maximum current for 500 ms			A	xx	xx
Maximum current for 10 ms			A	xx	xx
Remarks:					
Current data for the energy manager 400/480 V AC refer to the supply voltage for the supply unit. Between this overload a minimum pause of 5 minutes is to be maintained and the number of cycles limited to ??.					
1) Upon request xx not yet available at the time of going to press.					

Table 5.10 Current data, KeDrive D3-EM energy manager BG4

5.1.7 Technical data, KeDrive D3-ES energy storage

Type	Unit	D3-ES 300/A-A1xx
Energy storage		
Maximum voltage	V DC	400
Maximum useable voltage	V DC	390
Capacitance	mF	110
Cyclic current	A DC	200
Cyclic energy swing	kJ	5
Max. energy	kJ	7.8
Cycle duration (one charging and discharging process with specified energy swing)	s	1
Maximum current	A DC	800
Ambient temperature	°C	5...40, up to 55 with derating

Table 5.11 Technical data, KeDrive D3-ES



Note:

Until the type test is completed, all technical data are only calculated values and not assured characteristics!

5.1.8 Dimensions, energy manager and energy storage (heat sink)

	KeDrive D3-EM BG4	KeDrive D3-ES BG4
Type	KeDrive D3-EM 300/A-B2	KeDrive D3-ES 300/A-A1
Weight	Approx. 16 kg	Approx. 17 kg
B (width)	274	274
H (height)	430 ¹⁾	350 ¹⁾
T (total depth)	246	244
T1	222 ¹⁾	222 ¹⁾
H1	378	298
H2	6	
H3	390	310
A	27	27
A1 / A2 / A3 / A4	82 / 137 / 192 / 247	82 / 192 / 247
C	4.8	
D	80	80
Side clearance	Direct butt mounting	
Screws	9 x M4	8 x M4

Table 5.12 Dimensions, charging module and supply module (heat sink), all dimensions in mm, 1) Not including terminals + connectors

Figure 5.5 Dimensional sketches, KeDrive D3-EM energy manager

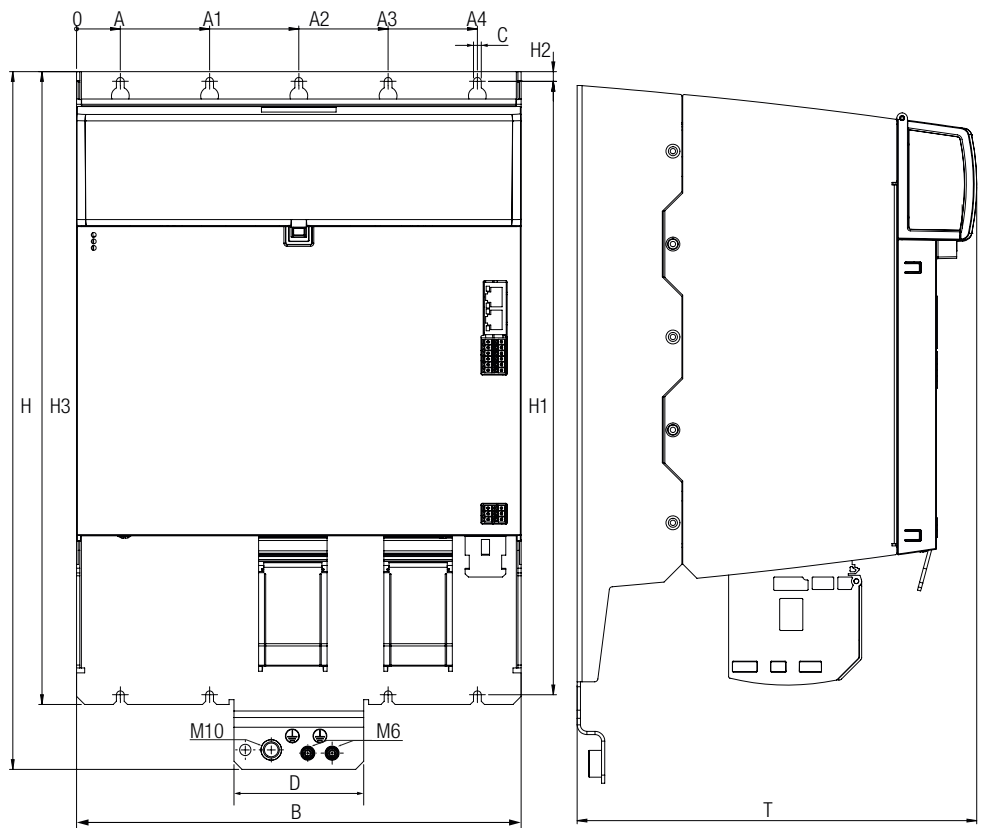
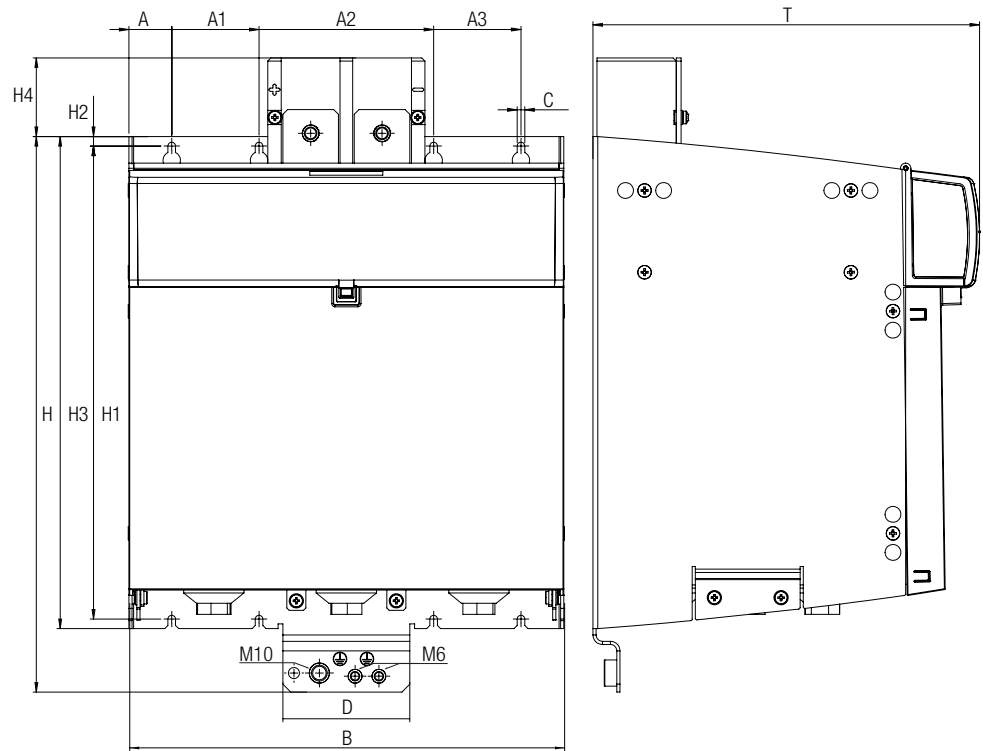

Figure 5.6 Dimensional sketches,
KeDrive D3-ES
energy storage



5.1.9 Dimensions, energy manager (liquid cooling)

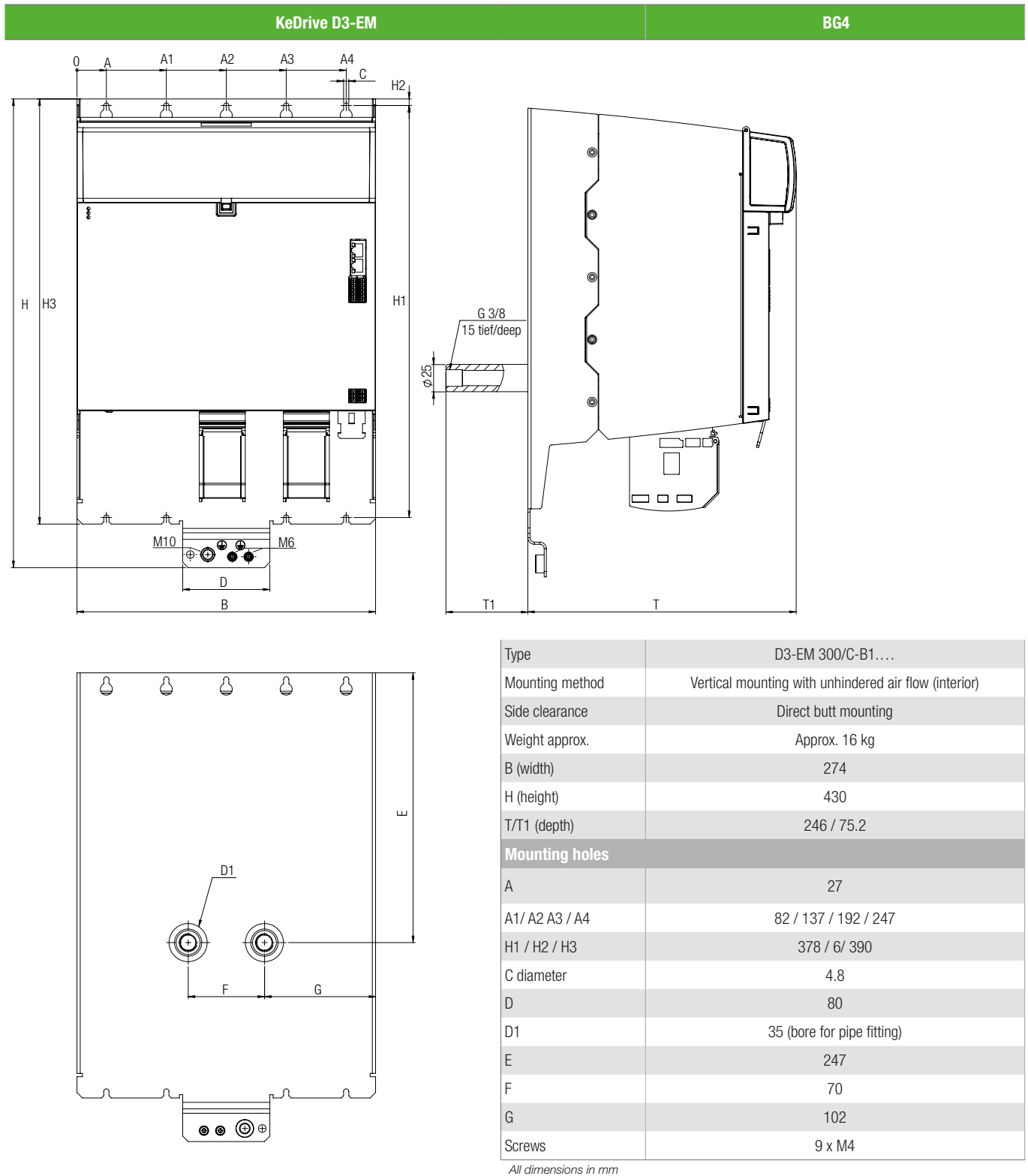

Figure 5.7 Dimensions, KeDrive D3-EM BG4 liquid cooling

5.1.10 Connector sets

For energy manager D3-EM 300/X-xx

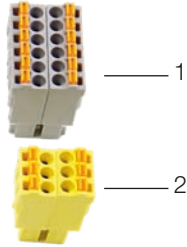

Figure	Order designation	Explanation
	D3-XT 227/A	Connector for connection V-MEAS
Figure	Order designation	Explanation
	D3-XT 230/A	1 = Connector for X25A (digital inputs) 2 = Connector for X26A (safe dig. inputs)
Figure	Order designation	Explanation
	D3-XT 23A/A	Connector for X28A (1+2 = TEMP, 3 = DO0, 4 = GND)

Figure	Order designation	Explanation
	D3-XT 230/D	Data cables RJ45 connector 0.3 m

For energy storage D3-ES 300/x-xx

Figure	Order designation	Explanation
	D3-XT 227/A	1 = Connector for connection V-MEAS

5.1.11 Accessories, choke module KeDrive D3-EL

The choke module is to be provided for the power connection between the energy manager and the energy storage.

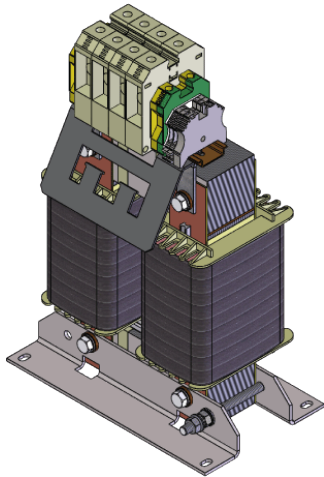

Figure 5.8 Choke module type D3-EL 120/A-0100-00

Technical data, general

Ambient conditions	Choke module D3-EL
Maximum voltage	800 V DC
Inductance	250 μ H
Switching frequency	4 kHz
Ambient temperature	0 °C to +40 °C, with power reduction up to +55 °C (1.5% / °C)
Installation altitude	Up to 3000 m
Rel. atmospheric humidity ¹⁾	15 ... 95%, condensation not permitted
Storage temperature	-25 °C to +70 °C
Insulation class	F
Protection class	I
Degree of protection	IP10
Perm. pollution degree	P2 as per EN 61558-1
Thermal configuration	$I_{\text{eff}} < I_N$
Temperature monitoring	Temperature switch (NC) 155 °C in winding (terminal T1/T2)
UL recognition	In preparation

¹⁾ In operation

Power-dependent technical data

Type	Rated current I_N [A]	Power dissipation total [W]	Inductance [mH]	Weight [kg]
D3-EL 120/A-0100-00	120	136	250	18

Dimensions (in mm)

Type	B (width)	H (height)	T (depth)	T1	A	C	D \emptyset
D3-EL 120/A-0100-00	240	367	144	180	220	121	M8

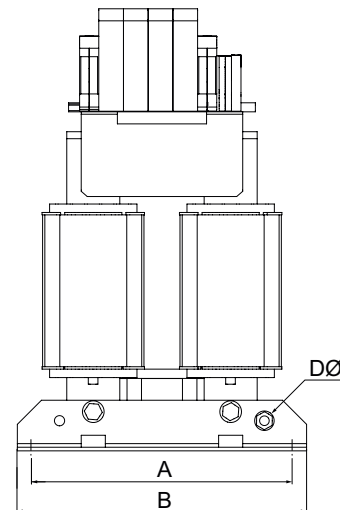
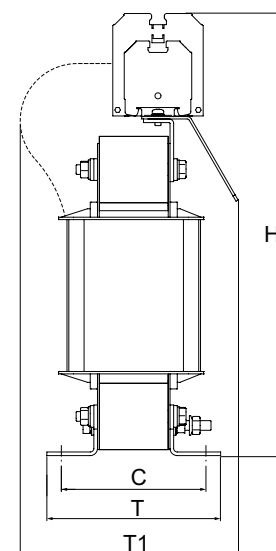
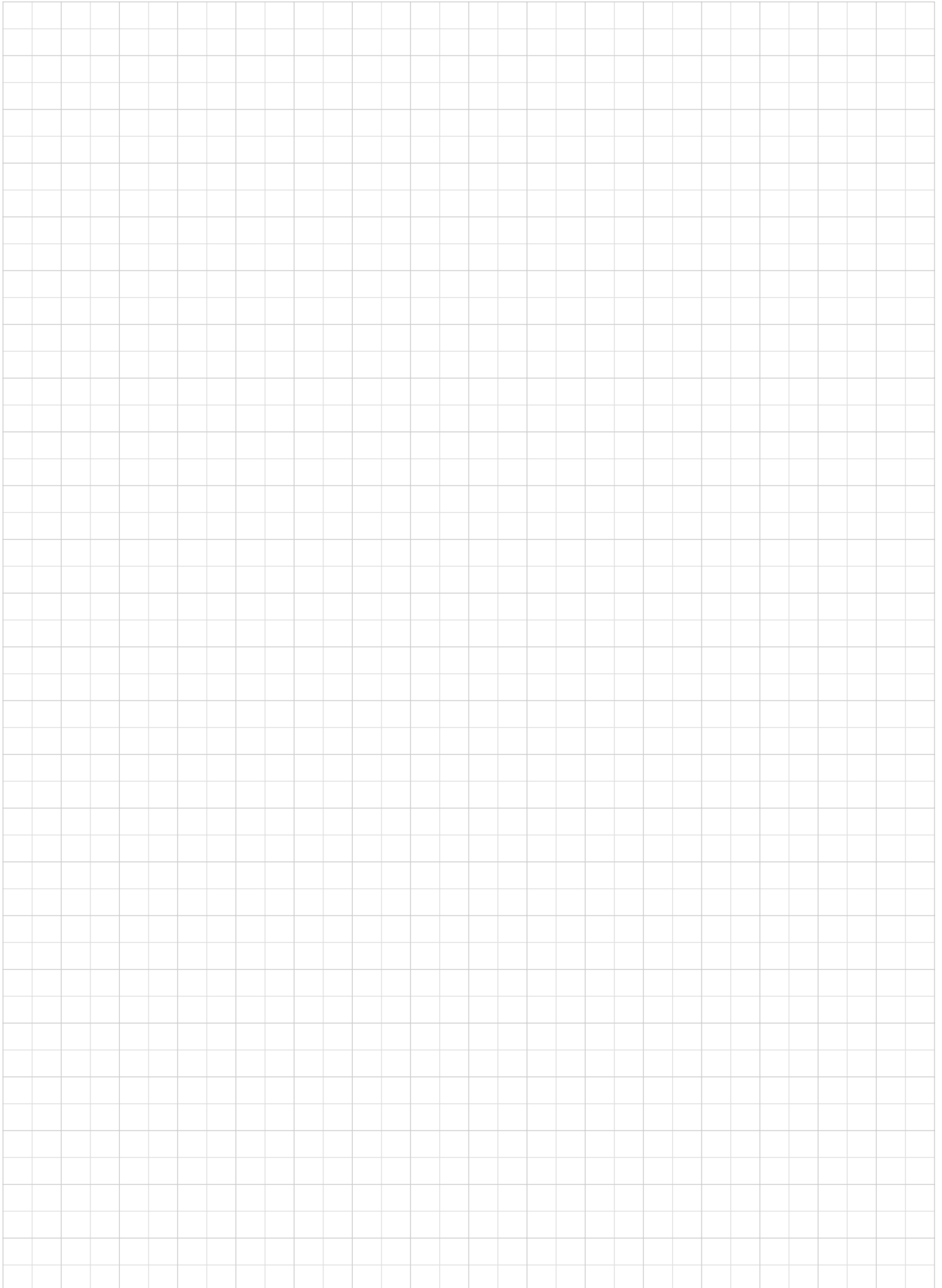

Fig.



Space for your notes

A large grid of graph paper for taking notes, consisting of 20 columns and 30 rows of small squares.

6 KeDrive D3 additional modules

6.1 KeDrive D3 system overview

Device	D3-DE 300 expansion module	D3-DC 300 capacitance module	D3-XV connection module
Fig.			
Operation manual / leaflet	1804.202B.x	1804.203B.x	1804.211B.0-00



NOTE:

The latest operation manuals and other documents are available in German, English and other languages and can be downloaded from our homepage

<https://www.keba.com/de/industrial-automation/service-support/downloads/doku-data-portal>

6.2 D3-DE 300 expansion module

The expansion module is used to protect, monitor and adapt the smaller cable cross-section (DC link = lower current-carrying capacity) of the axis controllers D3-DA 3xx BG1+2 to the larger cable cross-section (DC link = higher current-carrying capacity) of the axis controllers D3-DA 3xx BG3+4.

6.2.1 Overview of the connections, D3-DE 300 expansion module

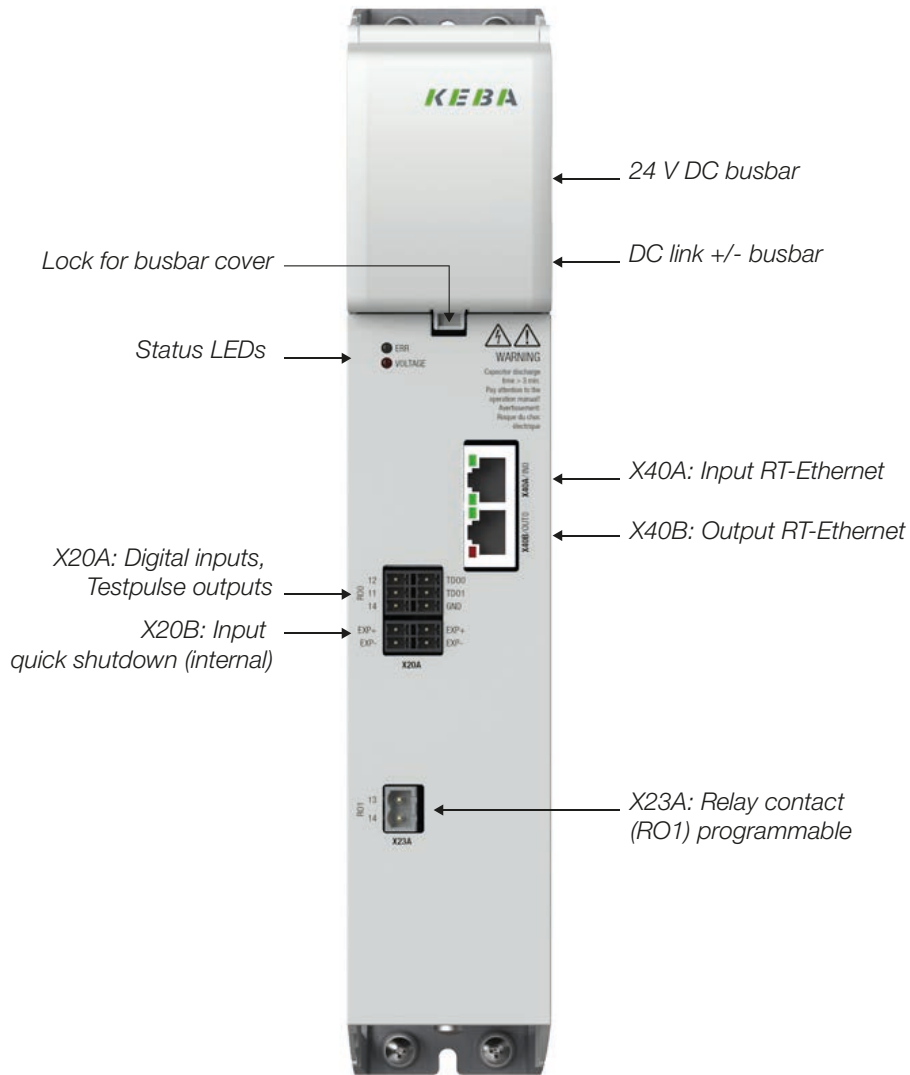

NOTE:

You will find descriptions and specifications for the above stated connections in the Operation Manual D3-DE 300 Expansion Module (ID. no.: 1804.202B.x-xx).

Included in the scope of supply		For details see
Expansion module	D3-DE 300/x-00x0	Chapter 6.2.3
Busbar elements	For 24 V DC supply and DC link power supply	-
Documentation	Document set	Chapter 7.2
Optional (not included in the scope of supply)		
Connector set	D3-XT 270/A, D3-XW 270-0xx	Chapter 6.2.5

6.2.2 Order code, D3-DE 300 expansion module

The article designation provides information about the related variant of the axis controller supplied. You will find the significance of the individual characters of the order code in the column on the left.

Name	D3	DE	3	0	0	/	A	-	0	0	0	0	0	0	1	-	0	0	0	0
Module type	Expansion module																			
Product line																				
Reserved	0: -																			
Reserved	0: -																			
Cooling	A: Heat sink B: Cooling plate																			
Reserved	0: -																			
Variant	0: Single 1: Dual 2: Dual End																			
Reserved	0: -																			
Options	0: Not including protective coating 1: Including protective coating																			
Hardware version	0:																			
Model	00: Not including product documentation ***) 01: Including product documentation (standard variant) 02: Including connector sets, not including product documentation ***) 03: Including connector sets, including product documentation																			
Field bus	0: RT-Ethernet coupler & cross-communication																			
Reserved																				

***) Only contract customers

6.2.3 Technical data, KeDrive D3 expansion module

D3-DE 300 expansion module	Unit	D3-DE 300/x-0000 Single	D3-DE 300/x-0010 Dual	D3-DE 300/x-0020 Dual End
Control section				
Mains input voltage $\pm 10\%$	V DC	24		24
Rated current consumption	A	0.25		0.25
Power dissipation	W	6.0		6.0
DC link (input = left, output = right side of device)				
Input voltage ¹⁾	V DC	565 to 678		565 to 678
Input current	A DC	35 to 29		70 to 64
Output voltage ¹⁾	V DC	565 to 678		565 to 678
Output current	A DC	35 to 29		2 x 39 to 2 x 32
Power section				
Continuous power P_N	kW	22		44
Peak power $2 \times P_N$ for 1 s	kW	44		88
Power dissipation in the interior	W	20		20
<i>1) The voltage is dependent on the supply unit D3-DP 300 and the supply voltage connected (3x400-480 V AC)</i>				

Table 6.13 Technical data, D3-DE 300

6.2.4 Installation and dimensions, D3-DE 300 expansion module

D3-DE 300	Unit	BG1 (Single/Dual/Dual End)
Weight approx.	kg	2.8
H (height)	mm	310
B (width)	mm	54.5
T/T1 (depth)	mm	241/222
Side clearance	mm	0 (direct butt mounted)
A	mm	27.5
C /C1	mm	299 / 6
D \varnothing	mm	5

Table 6.14 Dimensions and mounting clearances, D3-DE 300

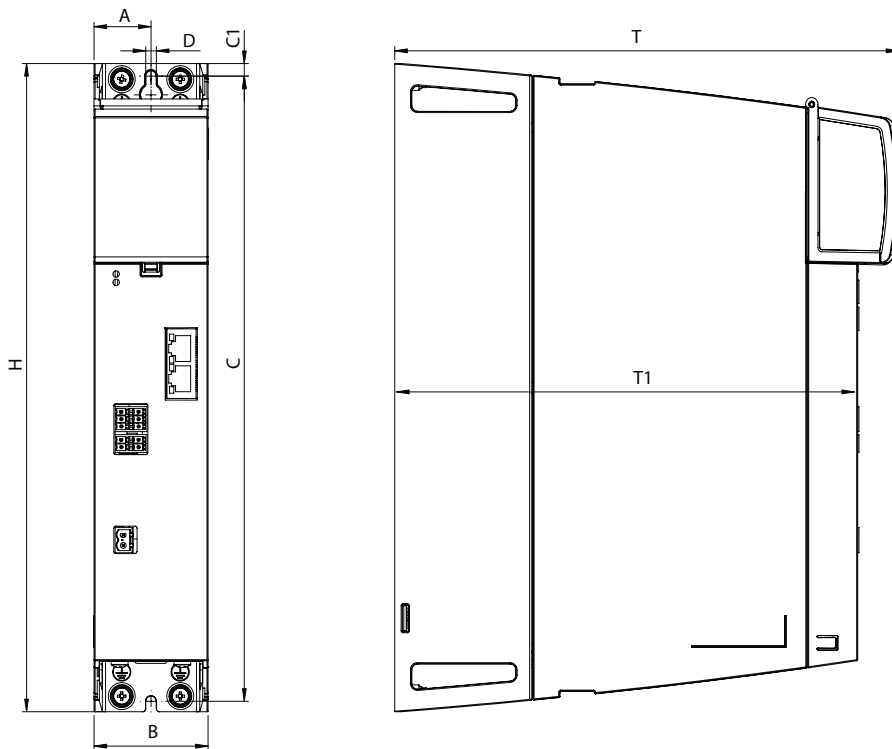

Figure 6.9 Dimensional drawing, D3-DE 300

6.2.5 Connector sets, D3-DE 300 expansion module

6

Figure	Order designation	Explanation
	<p>D3-XT 270/A for expansion module D3-DE 300</p>	<p>1 = Connector, 24 V DC control supply 2 = Connector, relay contact (R01) 3 = Connector, dig. inputs plus test pulse output plus quick shutdown</p>

*) Not yet available at the time of going to press

6.2.6 Connector set, DC link connection connectors

The set is required for the connection between Dual and Dual End.

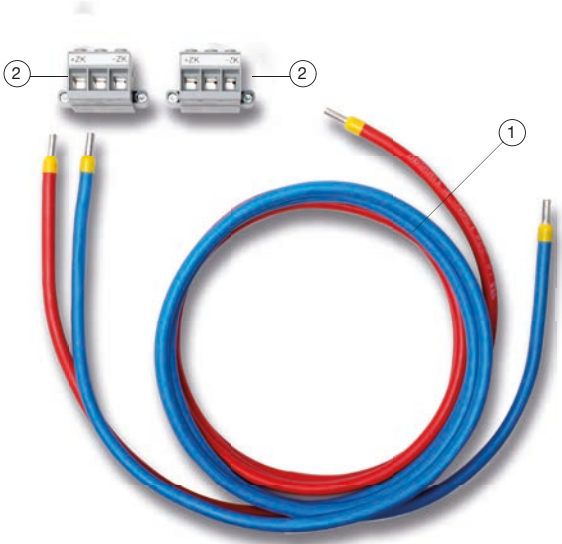
Figure	Order no.	Length	Acceptance	Item, fig.
				
	D3-XW 270-015	1.5 m	UL	(1)
	D3-XW 270-030	3.0 m	UL	(1)
	D3-XT 270/B	DC link connector *)		(2)

*) Two connectors are always required

6.3 D3-DC 300 capacitance module

The addition to the D3-DP 300 supply unit BG3+4 of the D3-DC 300 capacitance module makes possible usage in highly dynamic applications.

6.3.1 Overview of the connections



6



NOTE:

You will find descriptions and specifications for the above stated connections in the Operation Manual D3-DC 300 Capacitance Module (ID. no.: 1800.203B.x-xx).

Included in the scope of supply		For details see
Capacitance module	D3-DC 300/x	Chapter 6.3.3
Busbar elements	For 24 V DC supply and DC link power supply	-
Documentation	Document set	Chapter 7.2
Optional (not included in the scope of supply)		
Connector	D3-XT 275/A	Chapter 6.3.5

6.3.2 Order code

The article designation provides information about the related variant of the D3-DC 300 capacitance module supplied. You will find the significance of the individual characters of the order code in the column on the left.

Name	D3	DC	3	0	0	/	A	-	3	5	0	0	-	0	0	1	-	0	0	0	0
Module type	Capacitance module																				
Product line																					
Reserved	0: -																				
Reserved	0: -																				
Cooling	A: Heat sink																				
Capacitance	36: 3600 µF																				
Reserved	0: -																				
Reserved	0: -																				
Options	0: Not including protective coating 1: Including protective coating																				
Hardware version	0:																				
Model	00: Not including product documentation ***) 01: Including product documentation (standard variant) 02: Including connector sets, not including product documentation ***) 03: Including connector sets, including product documentation																				
Field bus	0: RT-Ethernet coupler & cross-communication																				
Reserved																					

***) Only contract customers

6.3.3 Technical data, KeDrive D3 capacitance module D3-DC 300

D3-DC 300 capacitance module	D3-DC 300/x-35xx-xx
DC link capacitance (C) [µF]	3600 ±10%
Maximum nominal mains voltage	The capacitance module is designed for operation in the intended KeDrive D3 system. The maximum nominal mains voltage from the supplying D3-DP 300 supply unit BG3+4 is allowed to be 277 V~/480 V~.
DC link discharging time	The DC link discharging time is dependent on the overall configuration of the axis group. Follow the safety instructions. Pay attention to warning sign on the device (see front of device).

Table 6.15 Technical data, D3-DC 300 capacitance module

6.3.4 Installation and dimensions, D3-DC 300 capacitance module

D3-DC 300 capacitance module	Unit	D3-DC 300/x-35xx-xx
Weight	kg	5.8
B (width)	mm	109
H (height) ¹⁾	mm	310
T (depth) ¹⁾	mm	251
A	mm	55
A1	mm	27
C	mm	299
C1	mm	6
T1	mm	222
D	mm	5
Fastening screws		4 x M4

All dimensions in mm.
 1) Without terminals/connectors.
 2) Also pay attention to the bending radius of the connection cables.

Table 6.16 Dimensions

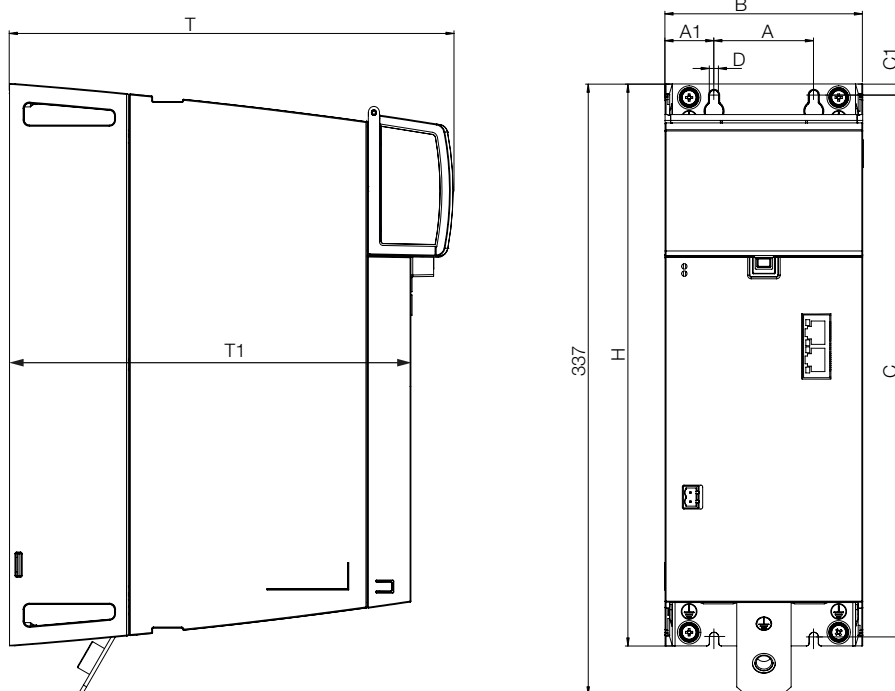

Figure 6.10 Dimensional drawing, D3-DC 300 module

6.3.5 Connector set for D3-DC 300

Figure	Order designation	Explanation
	<p>D3-XT 275/A for capacitance module D3-DC 300</p>	<p>Connector, 2-pin, for relay output X23A</p>

6.4 Connection module KeDrive D3-XV

The connection module is used to add a second row to the drive group.

6.4.1 Overview of the connections

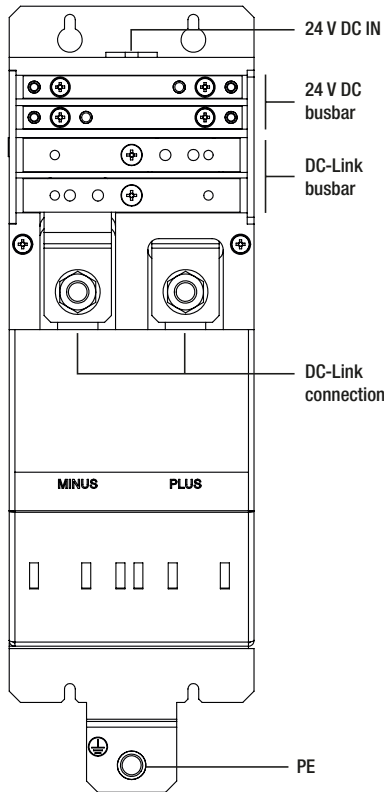

Figure 6.11 Connection module type D3-XV, connections

6.4.2 Technical data, KeDrive D3-XV

Ambient conditions	Connection module D3-XV
Maximum voltage	800 V DC
Rated current	300 A
Ambient temperature	0 °C to +40 °C, with power reduction up to +55 °C (1.5% / °C)
Installation altitude	Up to 3000 m
Rel. atmospheric humidity ¹⁾	15 ... 95%, condensation not permitted
Storage temperature	-25 °C to +70 °C
Insulation class	F
Protection class	I
Degree of protection	IP00
Perm. pollution degree	P2 as per EN 61800-5-1
Weight	2.1 kg
UL recognition	In preparation

¹⁾ In operation

6.4.3 Dimensions, KeDrive D3-XV

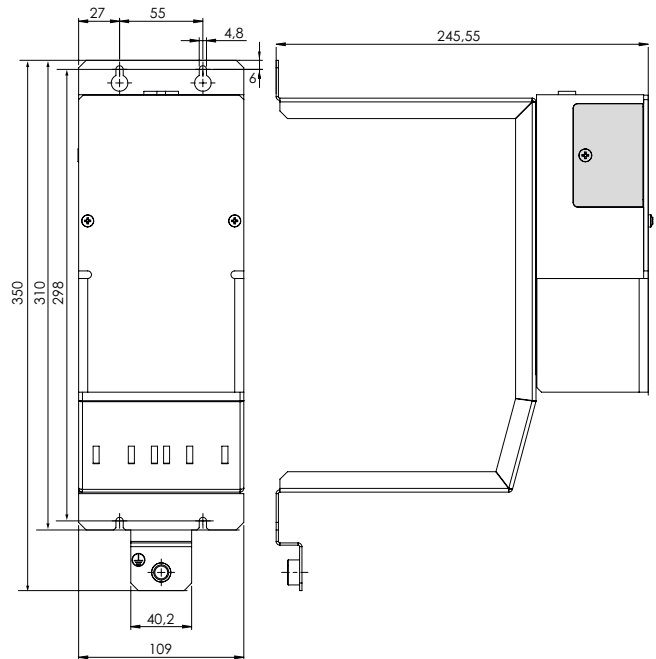

Figure 6.12 Connection module type D3-XV, dimensions



NOTE:

You will find details and specifications in the leaflet for the connection module KeDrive D3-XV (ID no.: 1804.211B.x).

7 KeDrive D3 Accessories

7.1 KeDrive D3 - accessories (additional components)



Contents	Comment	Page
Document set	Data carrier with booklet of safety instructions	Page 104
Accessory set	Axis controller and supply unit BG1+2	Page 105
Accessories for axis controllers	Ethernet cable	Page 105
Mains chokes	LR34.xx-UR	Page 107
Braking resistors	BR-xxx.xx-,xx-x-,UR	Page 109
Mains filters	EMCx.xxxx-UR and D3-XF0xx/A - xxx-UR	Page 116

7.2 Document set



Order designation	Contents
1020.850.0-xx	<p>Document set includes latest data carrier (DVD) with booklet and sleeve</p> <ul style="list-style-type: none"> Data carrier: contains user documents for all product ranges. Booklet (with DVD sleeve): contains safety instructions and application notes for electrical equipment in 24 EU languages plus Chinese
1020.855.0-xx (not including DVD for contract customers)	<p>Document set includes two booklets *)</p> <ul style="list-style-type: none"> Booklet 1: contains QR code for downloading all documents from our home page, as well as safety instructions and application notes for electrical equipment in 24 EU languages plus Chinese Booklet 2 "UL-Certification": includes all UL-related information for all product ranges

*) Not shown



NOTE:

Document set is included in the scope of supply of the drive components KeDrive D3.

7.3 Accessories for axis controllers

7.3.1 Accessory set for axis controllers BG1 + BG2

Figure	Order designation	Designation
	<p>D3-XT 230/B</p>	<p>1 = Ethernet cable, 4x2xAWG27/7 Length = 25 cm, industrial standard 2 = PE earthing strap</p>



NOTE:

EtherCAT connection cable of length 500 mm:

- You will need this cable if the D3-DP 300 supply unit BG2 is fitted in your KeDrive D3 system.
- It is included with the D3-DP 300 supply unit BG2.

7.3.2 Ethernet cable for axis controllers BG3

Figure	Order designation	Designation
	<p>D3-XT 230/C</p>	<p>1 = Ethernet cable. 4 x 2 x AWG 27/ 7 Length = 400 mm Industrial standard</p>

7.3.3 Ethernet cable for axis controllers BG4

Figure	Order designation	Designation
	D3-XT 230/D	Ethernet cable 4 x 2 x AWG 27/ 7 Length = 500 mm Industrial standard

7.3.4 Ethernet cable (standard)

	<p>CC-ECL03</p> <p>Cable length (m)</p>
Ethernet connection cable type CC-ECL03 (Ethernet)	Order designation

Technical data	CC-ECL03
Description	Connection cable between Ethernet connection on the axis controller and a PC with KeStudio DriveManager 5
Cable length	3 m
Cable type	Crosslink Ethernet cable, CAT 5
Connections	2 x RJ45 connectors
Article number	1109.0002

7.3.5 Ethernet cable (without cross-communication)

Figure	Order designation	Designation
	<p>XW 021-005 (0.5 m)</p> <p>XW 021-010 (1.0 m)</p> <p>XW 021-020 (2.0 m)</p>	Patch cable 2 x 2 x AWG 27/ 7 without cross-communication

7.4 Mains chokes

The usage of mains chokes reduces the peak system currents and therefore also the distortion (THD) in the system. In this way the life of the axis controllers and the supply units is increased.

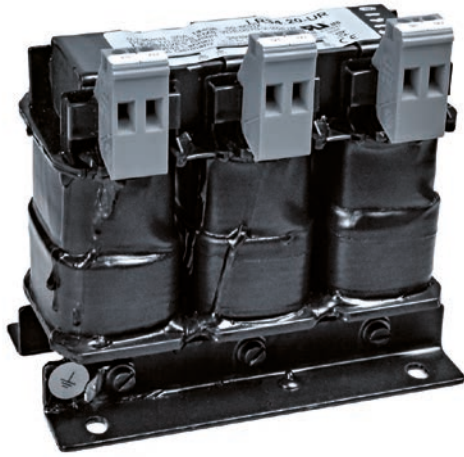

LR34.xx-UR
 Product range and voltage | Rated current

LR34.20-UR (example)

Article designation

Our recommendation for KeDrive D3-DP supply module BG1 and BG2

Device	Mains choke
D3-DP 300/A-10xx / D3-DP 300/B-10xx (BG1)	LR34.20-UR
D3-DP 300/A-22xx / D3-DP 300/B-22xx (BG2)	LR34.44-UR

The following mains chokes are pertinent to the KeDrive D3-DP supply module BG3 and BG4:

Device	Mains choke
D3-DP 301/x-45xx (BG3)	LR34.108-UR
D3-DP 301/x-90xx (BG3)	LR34.168-UR
D3-DP 301/x-A2xx (BG4)	LR34.250-UR



NOTE:

Due to different precharging technology and to reduce the system interactions, a mains choke is imperative for the D3-DP 300 BG3+4 supply module. It is also to be ensured that the mains choke is installed between the mains filter and the supply unit.

7

Ambient conditions	LR34.20-UR	LR34.44-UR to LR34.250-UR
Mains voltage	3 x 460 V -25% +10%, 50/60 Hz ¹⁾	
Overload factor	2.0 x I _N for 3 s	2.0 x I _N for 30 s
Ambient temperature	-25 °C to +40 °C, with power reduction up to 60 °C (1.3% per °C)	
Installation altitude	1000 m, with power reduction up to 2000 m (6% per 1000 m)	
Relative atmospheric humidity	15 ... 95%, condensation not permitted	
Storage temperature	-25 °C to +70 °C	
Degree of protection	IP00	
Short-circuit voltage	UK 2% (corresponds to 4.6 V at 400 V)	
Permissible pollution degree	P2 as per EN 61558-1	
Thermal configuration	I _{eff} ≤ I _N	
UL recognition	UL recognition for the USA and Canadian markets	

¹⁾ At mains frequency 60 Hz the power dissipation increases by approx. 5-10%

**NOTE:**

You will find descriptions and specifications for the mains chokes in the following documents:

- Line Chokes - Installation Manual (ID no.: 0925.00B.x-xx)

Three-phase mains chokes for KeDrive D3-DP supply modules

Article designation	Rated current [A]	U_k [%]	Power dissip. tot. [W]	Inductance [mH]	Total height [kg]	CU weight [kg]	Connection
LR34.20-UR	20	2	34	0.735	2.5	0.4	4 mm ²
LR34.44-UR	45	2	51	0.33	5.0	2.0	10 mm ²
LR34.108-UR	110	2	103	0.13	15		35 mm ²
LR34.168-UR	170	2	148	0.09	25		70 mm ²
LR34.250-UR	250	2	159	0.059	30		M12

Dimensions of the three-phase mains chokes for the KeDrive D3-DP supply modules

Article designation	B (width)	H (height)	T (depth)	A	C	D Ø
LR34.20-UR	125	120	75	100	55	5x8
LR34.44-UR	155	156	115	130	72	8x12
LR34.108-UR	230	277	180	180	122	9x12
LR34.168-UR	240	295	200	190	125	11x15
LR34.250-UR	300	270	205	240	120	11x25

Dimensional drawing

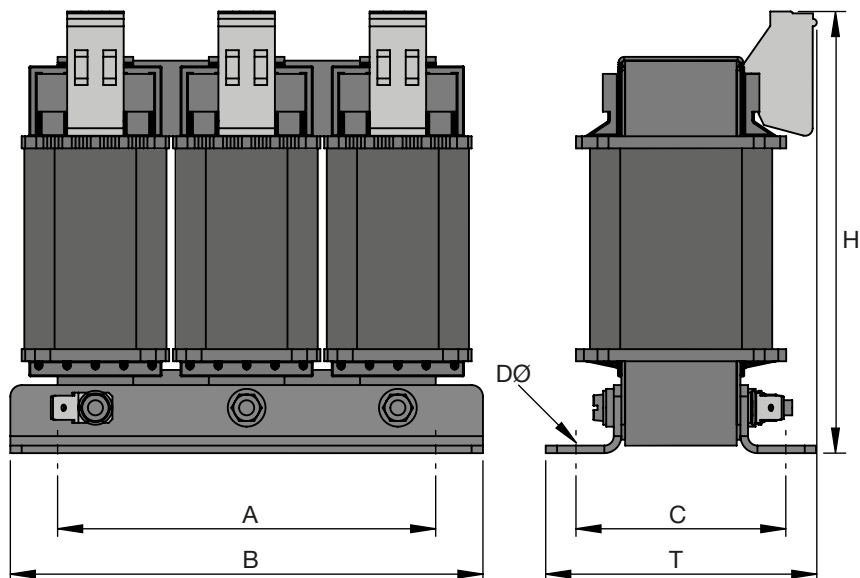

Dimensional drawing, three-phase mains choke

7.5 Braking resistors



NOTE:

Please note for KeDrive D3-DP supply module BG1+2 device variant with internal resistor:
Do not connect an additional braking resistor!

Please note for KeDrive D3-DP supply module device variant with external resistor:
Only operate supply unit **with** external braking resistor.

You will find further information in the Operation Manual KeDrive D3-DP (ID no.: 1404.201B.x-xx).

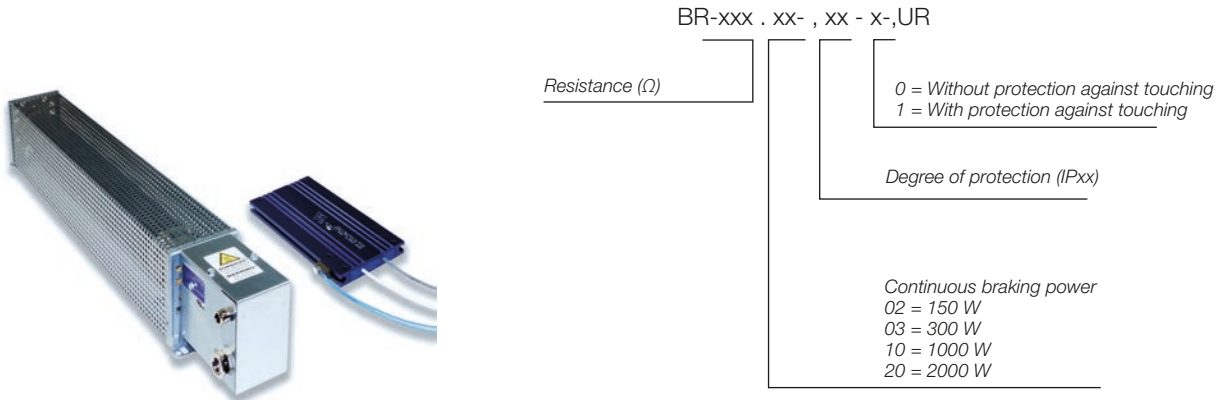

BR-XXX.XX.201-UR BR-XXX.XX.540-UR

Article designation

Design	Figure A1	Figure A2	Figure A3	Figure A4/A5	Figure A6
Technical data					
Surface temperature	> 250 °C				
Protection against touching	No			Yes	
Voltage max.	848 V DC		970 V DC	848 V DC	850 V DC
Test voltage	4.2 kV DC		4 kV DC	2.5 kV AC	
Breaking capacity of the temperature switch	6.3 A / 230 V AC 2.0 A / 24 V DC		0.5 A / 230 V AC	2 A / 230 V AC 2 A / 24 V DC	
Acceptance	CE-compliant; UL recognition				
Connection	1 m long - insulated litz wire			Terminal box with PG fitting	Studs in the device without PG fitting

Order desig.	Tech. data	Continuous braking power [W]	Resistance [$\Omega \pm 10\%$]	Peak braking power ¹⁾ [kW]	Connection: resistor/ temperature switch	Degree of protection	Fig.
BR-039.02.540-UR		150	39	3.3	AWG 14/22 (1.9/1.07 mm ²)	IP54	A1
BR-020.02.540-UR		150	20	3.3	AWG 14/22 (1.9/1.07 mm ²)	IP54	A1
BR-039.03.540-UR		300	39	6.6	AWG 14/22 (1.9/1.07 mm ²)	IP54	A2
BR-020.03.540-UR		300	20	30	AWG14/18	IP54	A3
BR-039.10.201-UR		1000	39	30	AWG 10/12 (6/4 mm ²)	IP20	A4
BR-020.10.201-UR		1000	20	30	AWG 10/12 (6/4 mm ²)	IP20	A4
BR-039.20.201-UR		2000	39	60	AWG 10/12 (6/4 mm ²)	IP20	A5
BR-020.20.201-UR		2000	20	60	AWG 10/12 (6/4 mm ²)	IP20	A5
BR-008.40.201-UR		4000	8	80	Stud terminal BK M8 AWG16-12 up to 2.5 mm ²	IP20	A6
BR-005.70.201-UR		7000	4.5	140		IP20	A6
BR-003.100.201-UR		10000	3.1	200		IP20	A6
VHPR 300 V 90R J		300	90	7.75	<i>Flying leads</i>	<i>IP54</i>	<i>A7</i>
VHPR 500 V 40R J		500	40	12.9	<i>Flying leads</i>	<i>IP54</i>	<i>Ax</i>
VHPR 500 V 55R J		500	55	12.9	<i>Flying leads</i>	<i>IP54</i>	<i>Ax</i>
RXLG-S1 1000W 36R J		1000	36	25.85	<i>Flying leads</i>	<i>IP54</i>	<i>Ax</i>
RXLG-S1 1000W 40R J		1000	40	25.85	<i>Flying leads</i>	<i>IP54</i>	<i>Ax</i>

1) For a duty cycle ED = 1% and a cycle time of max. 120 s

Our recommendation for device variants with external braking resistor:

- Use BR-039.xx.xxx-UR for KeDrive D3-DP - BG1 (10 kW).
- Use BR-020.xx.xxx-UR for KeDrive D3-DP - BG2 (22 kW).
- Use BR-008.40.xxx-UR for KeDrive D3-DP - BG3 (45 kW).
- Use BR-005.70.xxx-UR for KeDrive D3-DP - BG3 (90 kW).
- Use BR-003.100.xxx-UR for KeDrive D3-DP - BG4 (120 kW).

Dimensions, braking resistors [mm]

Dimensions [mm]	B (width)	H (height)	T (depth)	A	C3	Fig.
BR-039.02.540-UR	90	160	15	-	-	A1
BR-020.02.540-UR	90	160	15	-	-	A1
BR-039.03.540-UR	90	320	15	-	-	A2
BR-020.03.540-UR	41	320	122	-	-	A3
BR-039.10.201-UR	92	749	120	-	-	A4
BR-020.10.201-UR	92	749	120	-	-	A4
BR-039.20.201-UR	185	749	120	-	-	A5
BR-020.20.201-UR	185	749	120	-	-	A5
BR-008.40.201-UR	295	490	260	270	355	A6
BR-005.70.201-UR	395	490	260	370	455	A6
BR-003.100.201-UR	595	490	270	570	655	A6
VHPR 300 V 90R J	217	60	31	-	-	A7a
VHPR 500 V 40R J	337	60	31	-	-	A7b
VHPR 500 V 55R J	337	60	31	-	-	A7b
RXLG-S1 1000W 36R J	400	108	50	-	-	A7c
RXLG-S1 1000W 40R J	400	108	50	-	-	A7c

For dimensional sketches, see next page

Dimensional sketches, braking resistors

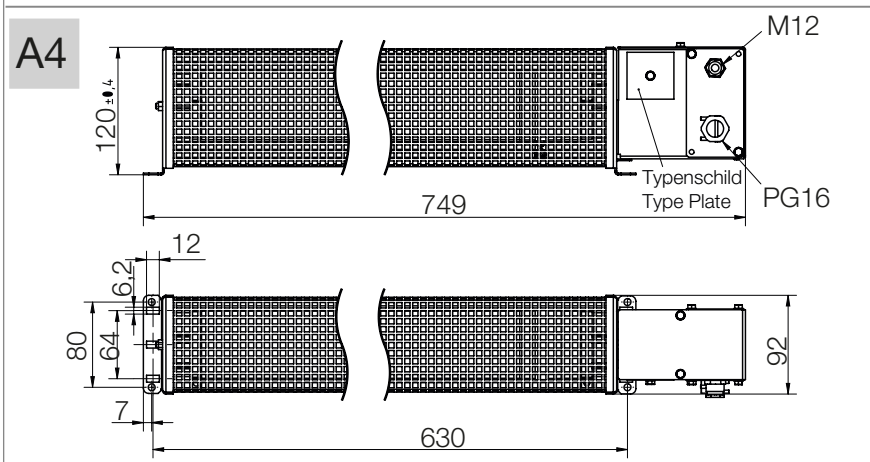
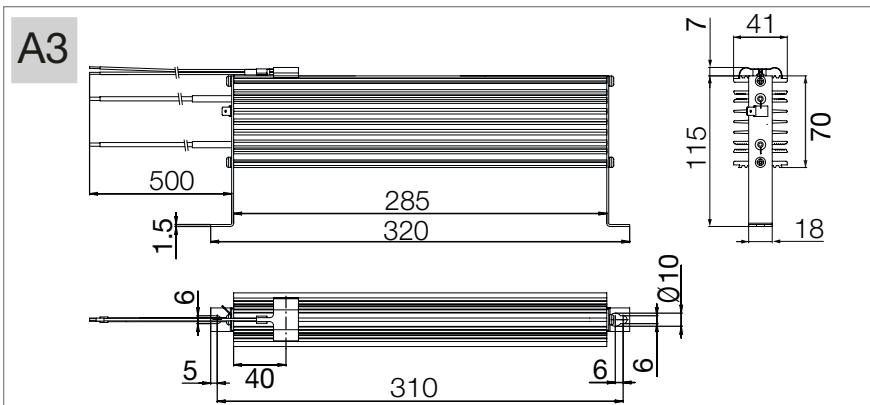
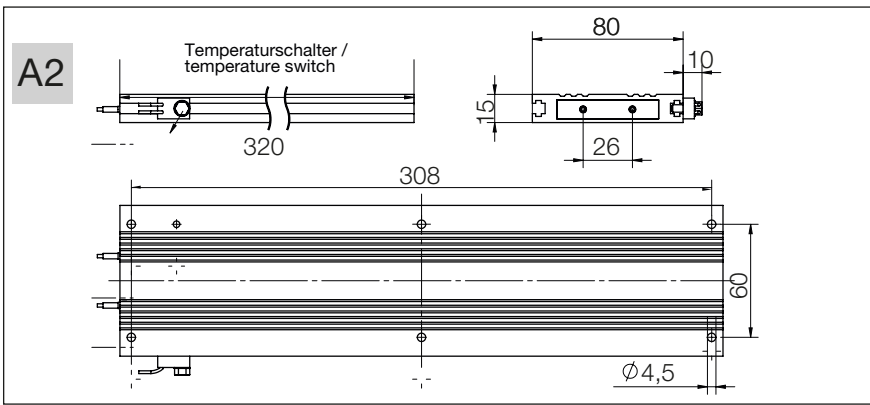
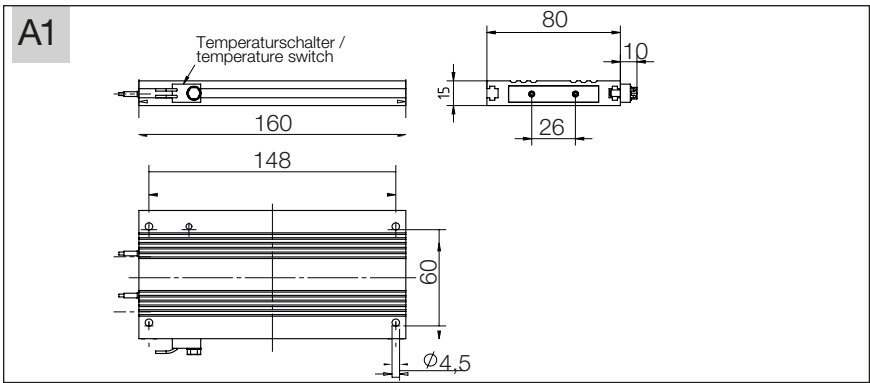

Dimensional sketches, braking resistors part II

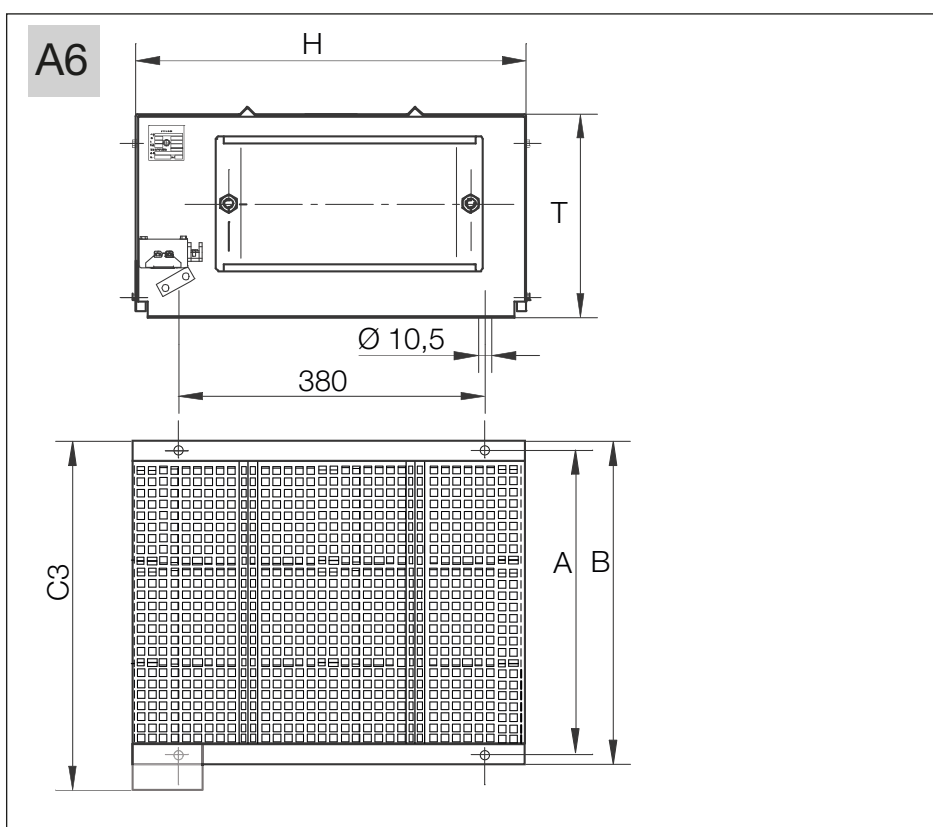
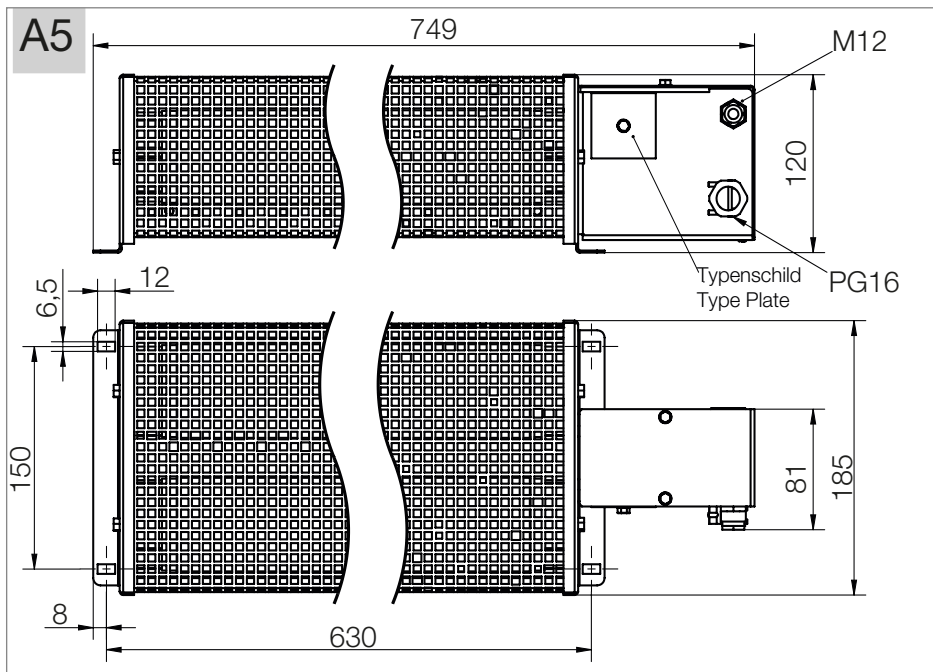

7

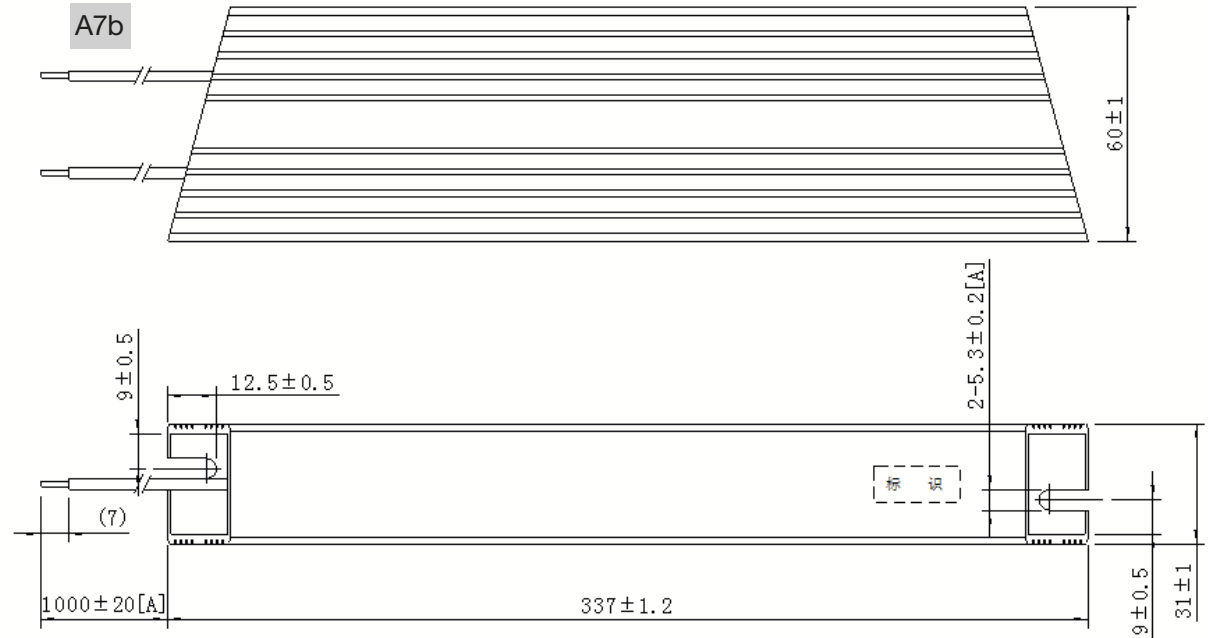
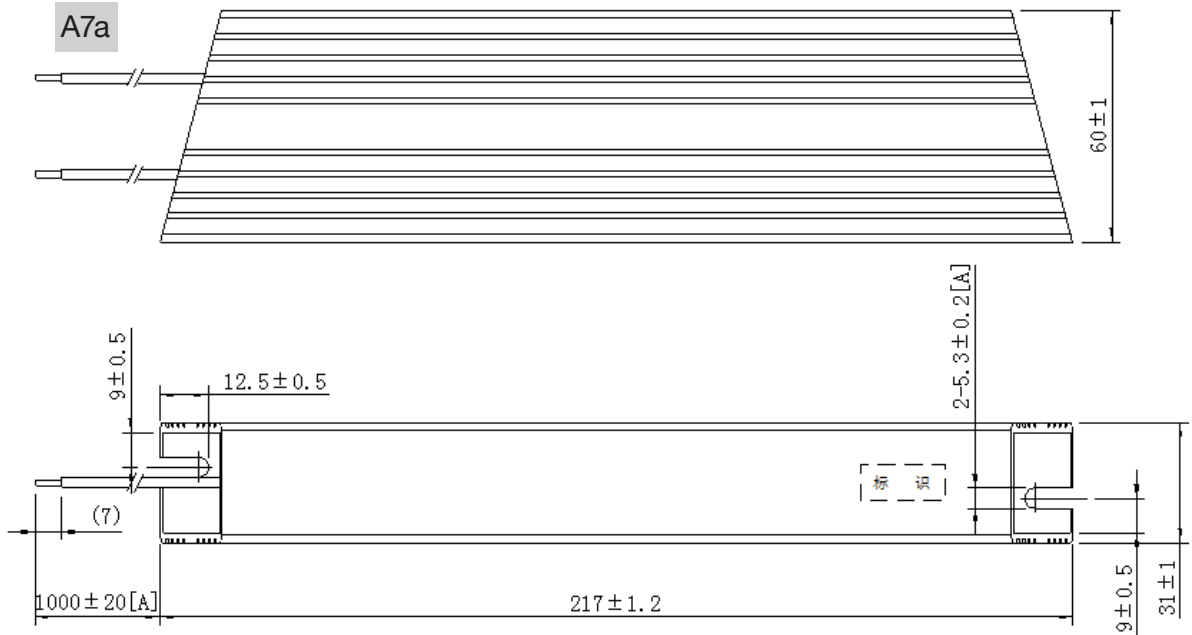

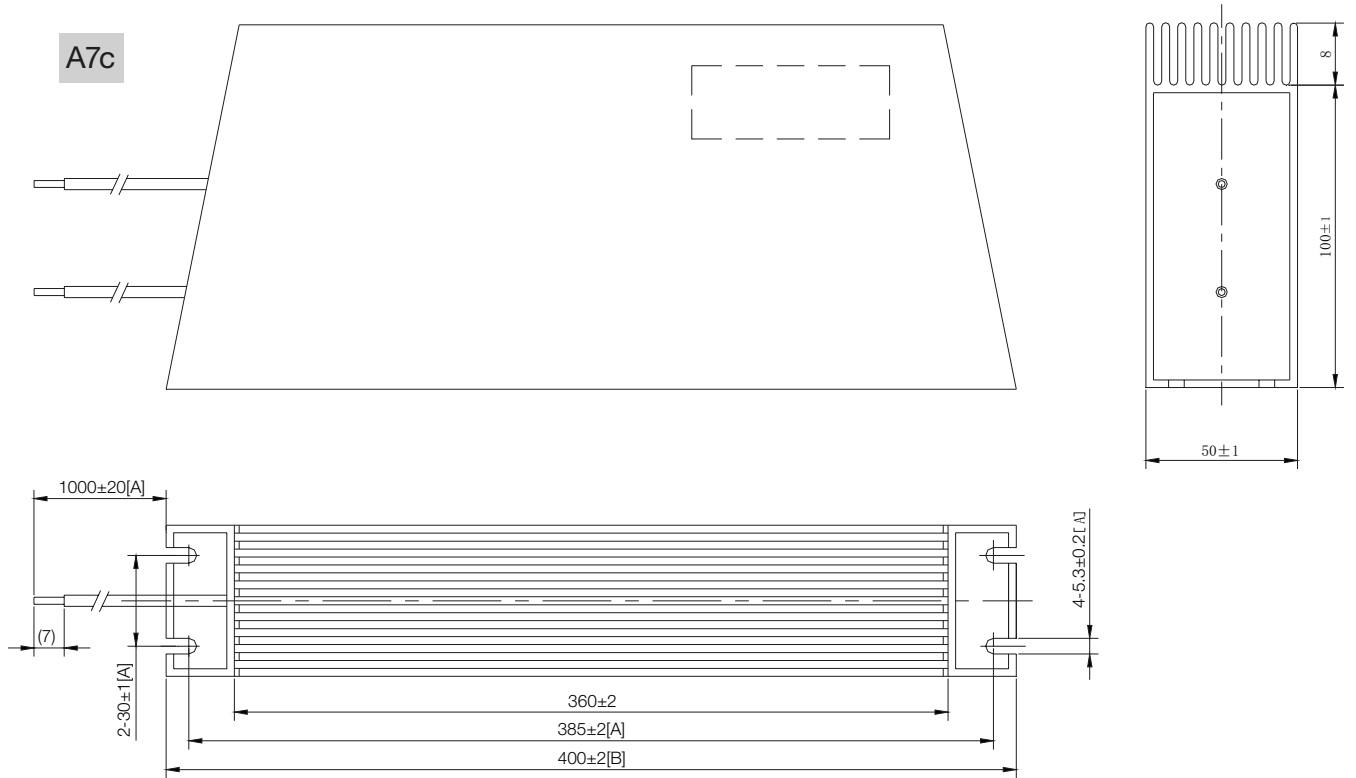

7.6 Mains filters



EMC25.240-UR

		EMC		2	5	.	1	2	0	-	U	R
Module type	Mains filter											
Rated current	25 A			25								
	53 A			53								
	85 A			85								
	165 A			165								
	221 A			221								
Variant	Reserved											
Motor cable length max.	120 m										120	
	240 m										240	
	300 m										300	
	600 m										600	
UL	00: None											
	UR: UL-recognised											

Technical data, general	EMCxx.xxx-UR
Rated voltage/frequency	3 x 480 V AC +10% at 50/60 Hz ¹⁾
Ambient temperature	Max. +45 °C, with power reduction up to 55 °C (1.0% per °C)
Installation altitude	1000 m, with power reduction up to 2000 m (1% per 100 m)
Relative atmospheric humidity	≤75% annual average, ≤95% for max. 30 days, aggressive atmosphere or condensation not permitted
Storage/transportation temperature	-25 °C to +55 °C / -25 °C to +70 °C
Climate category	25/105/21
Degree of protection	IP20/ IP00
Connections	Touch-protected terminals IP20, shield contact area (EMC25.xxx-UR to EMC53.xxx-UR and EMC85.300.1-UR) Busbars IP00 (EMC165.300.1-UR and EMC221.300.1-UR)
Standards/certificates	IEC 60939-2, RoHS-compliant, UL recognition ²⁾
RFI suppression to EN61800-3 (category C3 - industrial -)	EMCxx.120-UR: permitted motor cable length up to 120 m EMCxx.240-UR: permitted motor cable length up to 240 m EMCxx.300-UR permitted motor cable length up to 300 m EMCxx.600-UR: permitted motor cable length up to 600 m
RFI suppression to EN61800-3 (category C2 - residential -)	Dependent on switching frequency (see table)

1) At mains frequency = 60 Hz the power dissipation is approx. 10% higher! 2) UL for EMC85.300.1-UR, EMC165.300.1-UR and EMC221.300.1-UR in preparation



D3-XF xxx/A-xxxx-01

	D3 -	XF	0	2	5	/	A	-	0	6	1	2	-	U	R
Module type	Mains filter														
Rated current	25 A	(BG1)	025												
	53 A	(BG2)	053												
Variant	Reserved						A								
Number of axes	6 axes									06					
	12 axes									12					
Motor cable length max.	120 m														12
	240 m														24
	600 m														60
UL	00: None														U
	UR: UL-recognised														R

Technical data, general	D3-XF xxx/A-xxxx-xx
Rated voltage/frequency	3 x 480 V AC +10% at 50/60 Hz ¹⁾
Ambient temperature	Max. +45 °C, with power reduction up to 55 °C (1.0% per °C)
Installation altitude	1000 m, with power reduction up to 3000 m (1% per 100 m)
Relative atmospheric humidity	≤75% annual average, ≤95% for max. 30 days, aggressive atmosphere or condensation not permitted
Storage/transportation temperature	-25 °C to +55 °C / -25 °C to +70 °C
Climate category	25/105/21
Degree of protection	IP20/ IP00
Connections	Touch-protected terminals IP20, shield contact area (D3-XF 025/A-xxxx-xx to D3-XF 053/A-xxxx-xx) Busbars IP00 (D3-XF 085/A-xxxx-xx to D3-XF 221/A-xxxx-xx)
Standards/certificates	IEC 60939-2, RoHS-compliant, UL recognition ²⁾
RFI suppression to EN61800-3 (category C2 - residential -)	D3-XF xxx/A-0612-xx: Permitted motor cable length up to 120 m, up to 6 axes D3-XF xxx/A-1224-xx: Permitted motor cable length up to 240 m, up to 12 axes D3-XF xxx/A-1260-xx: Permitted motor cable length up to 600 m, up to 12 axes

¹⁾ At mains frequency = 60 Hz the power dissipation is approx. 10% higher!

7.6.1 Mains filter dimensioning

The following tables provide an initial estimation of which mains filter will probably meet the EMC requirements for a given requirement. The selection is to be checked by the installer/operating organisation. Under certain conditions it is possible to change to a smaller filter, or a larger filter must be used.

Step	Action
1.	Select the table that corresponds to the rated current for your application.
2.	Add together the motor cable lengths for your application and go to the related column or the next larger column.
3.	Select the corresponding environment for your application (residential C2 or industrial C3)
4.	Select the maximum motor power stage clock frequency that occurs in your application.
5.	Read off the article designation for the mains filter.
6.	Demonstrate compliance with EMC requirements by measurement.

Example

The system on which the interference is to be suppressed consists of six axes each with a motor cable length of 4 m and is operated with an automatically switching clock frequency with a maximum of 8 kHz also in residential areas. The mains-side rated current is 18 A.

- Based on the rated current, the Table "Mains input current $I_{IN} \leq 25 \text{ A}$ " is to be selected.
- The sum of the motor cable lengths is $6 \times 4 \text{ m} = 24 \text{ m}$, the column "30" is to be selected.
- Residential environment = category C2
- Maximum clock frequency = 8 kHz
- The recommendation for the mains filter is EMC25.240-UR

For table see below and next page

Complying with the EMC Directive

Commissioning, i.e. starting up intended usage of your machine or system, is only permitted while strictly complying with the EMC Directive (2014/30/EU).

The installer/operating organisation must provide proof of compliance with the protection targets stipulated in the standard.

The essential EMC measures are already implemented in the design of the devices in the form of optimised housing shielding, printed circuit board layout, filter measures and selection of suitable connectors with shield plate.

In addition to the internal measures, the following installation measures are to be noted:

- Lay cables for effective EMC
- Use shielded cables to suppress the interference emissions.
- Use further shielding measures such as proper shield connection using shield plates, etc.
- Use mains filters and mains chokes to limit cable-borne interference emissions effectively.

Mains input current $I_N \leq 25\text{ A}$

Max. motor cable length [m]		20	30	40	50	60	70	80	90	100	120	140	240	300	600		
Category	C2	Clock frequency [kHz]	4	EMC25.120-UR	EMC25.240-UR				EMC25.600-UR	D3-XF 025/A-0612-00	D3-XF 025/A-1260-00						
			8	EMC25.120-UR	EMC25.240-UR			EMC25.600-UR			N/A						
			16	EMC25.240-UR			N/A										
	C3	Clock frequency [kHz]	4	EMC25.120-UR								EMC25.240-UR		EMC25.600-UR			
			8	EMC25.120-UR								EMC25.240-UR		EMC25.600-UR			
			16	EMC25.120-UR								N/A					

Table 7.17 Matrix, use of mains filters depending on the motor cable length, category and clock frequency of the drive controller $I_N \leq 25\text{ A}$

Supply unit BG1	Article designation, filter
KeDrive D3-DP 300/x-10xx	EMC25.120-UR
	EMC25.240-UR
	EMC25.600-UR
	D3-XF 025/A-0612-00
	D3-XF 025/A-1260-00

Table 7.18 Selection of mains filter for KeDrive D3-DP BG1

Mains input current $I_{IN} \leq 53$ A

Max. motor cable length [m]		20	30	40	50	60	70	80	90	100	120	140	240	300	600
Category	C2	Clock frequency [kHz]	4	EMC53.120-UR	EMC53.240-UR	EMC53.600-UR		D3-XF 053/ A-0612-00		D3-XF 053/A-1260-00					
		8	EMC53.240-UR	EMC53.600-UR		N/A									
		16	EMC53.240-UR	EMC53.600-UR	N/A										
	C3	Clock frequency [kHz]	4	EMC53.120-UR								EMC53.240-UR		EMC53.600-UR	
		8	EMC53.120-UR								EMC53.240-UR		EMC53.600-UR		
		16	EMC53.120-UR								EMC53.240-UR		N/A		

Table 7.19 Matrix, use of mains filters depending on the motor cable length, category and clock frequency of the drive controller $I_{IN} \leq 53$ A

Supply unit BG2	Article designation, filter
KeDrive D3-DP 300/x-22xx	EMC53.120-UR
	EMC53.240-UR
	EMC53.600-UR
	D3-XF 053/ A-0612-00
	D3-XF 053/A-1260-00

Table 7.20 Selection of mains filter for KeDrive D3-DP BG2

Mains input current $I_{IN} \geq 53$ A

Max. motor cable length [m]		20	30	40	50	60	70	80	90	100	120	140	240	300	
Category	C3	Clock frequency [kHz]	4	EMC85.300.1-UR, EMC165.300.1-UR, EMC221.300.1-UR											
		8													
		16													

Table 7.21 Matrix, use of mains filters depending on the motor cable length, category and clock frequency of the drive controller $I_{IN} \geq 53$ A

Supply unit BG3+4	Article designation, filter
D3-DP 300/x-45xx	EMC85.300.1-UR
D3-DP 300/x-90xx	EMC165.300.1-UR
D3-DP 300/x-A2xx	EMC221.300.1-UR

Table 7.22 Selection of mains filter for KeDrive D3-DP BG3+4

7.6.2 Power-dependent technical data, three-phase mains filters

Article designation	Rated current I_N [A]	Overload current [A] / phase	Power dissipation [W]	Leakage current ²⁾ [mA]	Touch current ³⁾ [mA]	Clamping area
EMC25.120-UR	25	$2 \times I_N$ for 10 s ¹⁾	3	5.5	5.4	0.2 to 6.0 mm ² 1.5 to 1.8 Nm
D3-XF 025/A-0612-00	25		4.7	26.8	7.9	
EMC25.240-UR	25		4.8	24.5	7.2	
D3-XF 025/A-1260-00	25		9.8	53.7	8.0	
EMC25.600-UR	25		6.9	43.0	15.6	0.5 to 16.0 mm ² 2.0 to 2.3 Nm
EMC53.120-UR	53		16	5.7	5.9	
EMC53.240-UR	53		13.6	24.5	7.2	
D3-XF 053/A-0612-00	53		13.3	26.8	7.9	
EMC53.600-UR	53		14.3	43.0	15.6	
D3-XF 053/A-1260-00	53		18.7	53.7	8.0	
EMC85.300.1-UR	85		39	19.8	-	10/16 - 50 mm ²
EMC165.300.1-UR	165		41.6	18.1	-	Ring lug hole $\varnothing = 10.5$ mm for busbar
EMC221.300.1-UR	221		64.5	18.1	-	

1) For 10 s, repeatable after 6 minutes; precondition: mains filter mounted vertically on bare metal base plate.

2) Effective value of leakage current according to EN 60939 (2009) at 50 Hz and rated voltage with 2% asymmetry. The device on which the interference is to be suppressed can increase the leakage current.

3) Peak value measurement with measurement circuit according to EN 60990 at 50 Hz and rated voltage with 2% asymmetry.

7.6.3 Dimensions, three-phase mains filters

Article designation	Dimensions [mm]							PE	Input/output		Weight [kg]
	A	B	C	D	E	F	\varnothing		Clamping area (mm ²)	Tightening torque (Nm)	
EMC25.120-UR	310	55	220	260	300	-	5.3	M5	0.2 - 6	1.5 - 1.8	4.0
D3-XF 025/A-0612-00	270	62	115	256	40	240		M5	0.2 - 6.0	1.5 - 1.8	
EMC53.120-UR	310	55	220	260	300	-	5.3	M5	0.5 - 16	2.0 - 2.3	4.1
D3-XF 025/A-1260-00	310	54.5	221	260	291	299	5.3	M5			
EMC25.240-UR	310	55	220	260	300	-	5.3	M5	0.2 - 6	1.5 - 1.8	4.6
EMC53.240-UR	310	55	220	260	300	-	5.3	M5	0.5 - 16	2.0 - 2.3	4.8
EMC25.600-UR	310	55	220	260	300	-	5.3	M5	0.2 - 6	1.5 - 1.8	5.3
D3-XF 053/A-0612-00	270	62	115	256	40	240		M5	0.5 - 16.0	2.0 - 2.3	
EMC53.600-UR	310	55	220	260	300	-	5.3	M5	0.5 - 16	2.0 - 2.3	5.9
D3-XF 053/A-1260-00	310	54.5	221	260	291	299	5.3	M5			
EMC85.300.1-UR	310	115	210	270	295	70	6.5	M10	10 ¹⁾ / 16 - 50 ²⁾	7.0 - 8.0	5.7
EMC165.300.1-UR	420	110	250	370	405	80	6.5	M10	Busbars with bore $\varnothing 10.5$ mm ³⁾		9.8
EMC221.300.1-UR	420	150	250	370	405	100	6.5	M10			12.2

1) Solid wire 2) Flexible wire 3) See dimensional drawing

Dimensional drawings

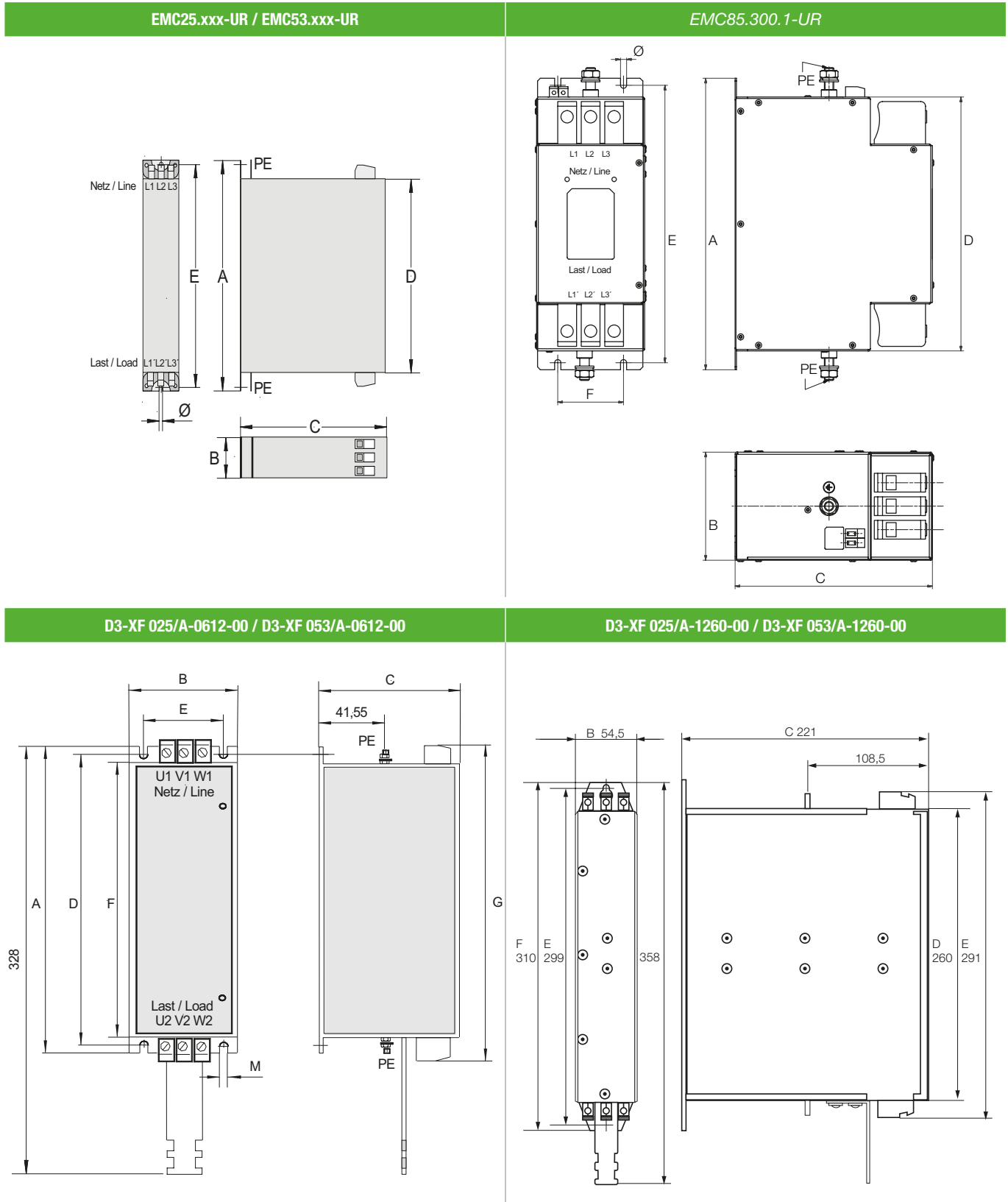

EMC165.300.1-UR

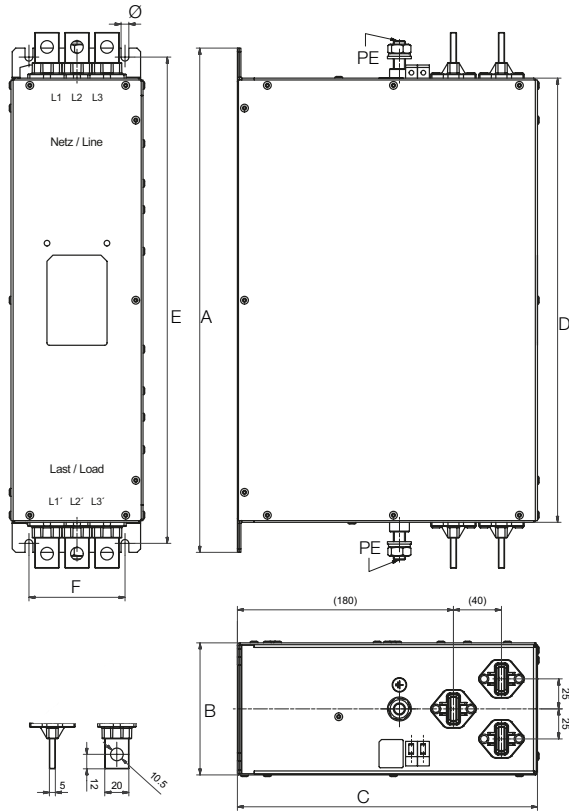

EMC221.300.1-UR

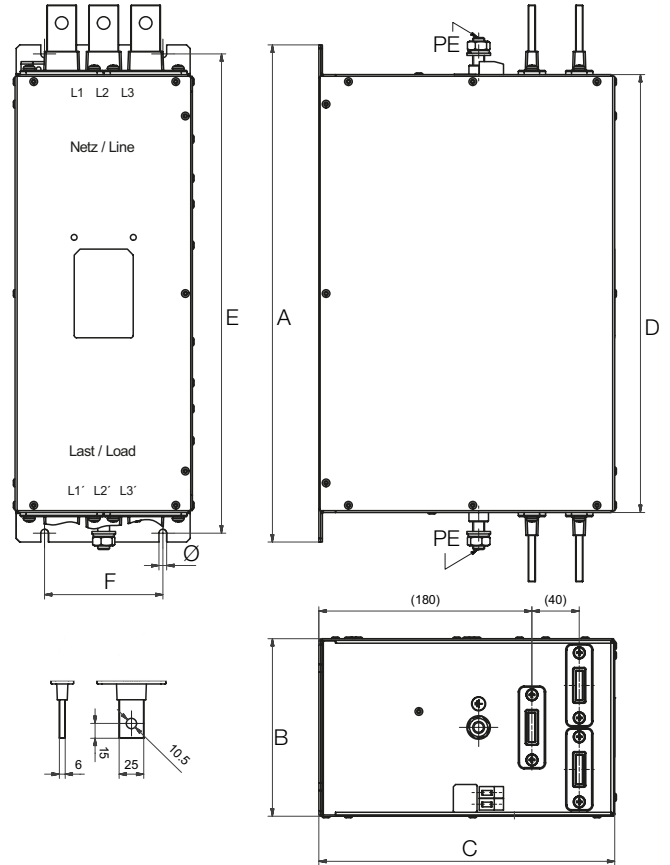

8 Engineering software with KeStudio

Effizientes Engineering mit KeStudio



www.keba.com

KEBA
Automation by innovation.

www.keps.com

Automation by innovation.
KEBA

8.1 Engineering software Kemro X



Kemro X
One System

Article designation: Engineering Environment Kemro X

Description:

KeStudio is the all-in-one engineering suite for all phases of the automation process. It is the development environment for automation solutions with the D3 and C5 controller product ranges and with the technology packages from IEC PLCs, robotics and machine tools.

From configuration, through programming, efficient drive commissioning to diagnostics and simulation, KEBA customers are offered a consistent engineering environment.

Properties:

- Intuitive wizards for quick commissioning
- Impressive HMI designer with many modules and layouts
- 3D simulation for high-performance optimisations
- Effective diagnostics for maximum machine availability
- Maximum flexibility due to IEC 61131-3 and C/C++ programming

Ordering information:

General	
Contents	Engineering tools and VisuFrameworks Simulation service (simulation runs on engineering PC)
Form of delivery	Download (approx. 8 GB, link required)
System requirements	
Operating system	Windows 10, Windows 11 Windows XP, Windows Vista, Windows 7 (support will be discontinued from release V5.20.0)

Licences

For the perpetual usage of the KeStudio Tool Suite, one of the two software licences is required:

Name	Description
KeStudio Engineering, annual	Single user licence for PC, period of use limited to one year

8.2 PC user software - KeStudio DriveManager

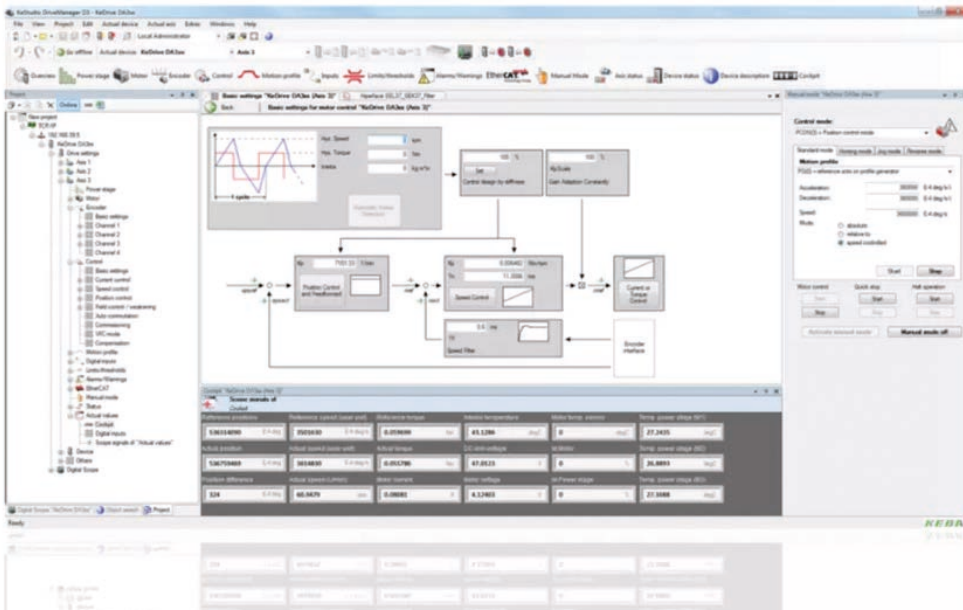

Description

The graphic PC user software DriveManager is an engineering tool for the configuration, commissioning, service and diagnostics of all drive product ranges from KEBA.

DriveManager has network support and is able to manage multiple axis controllers simultaneously in one project.

KeStudio DriveManager is available as part of the KeStudio setup of the automation system Kemro X or as a standalone application.

Support during the following tasks:

- Initial commissioning of one or more servocontrollers
- Quick serial commissioning with a configurable commissioning file (containing firmware, parameters, iPLC program)
- Operation and diagnostics, including using Cockpit and 6-channel oscilloscope
- Firmware update for the axis controllers and additional components
- Testing and commissioning of individual axes via manual mode function
- Project management
- Work offline using device repositories provided



NOTE:

KeStudio DriveManager is not optimised for usage on mobile touch devices such as tablets or smartphones.

Licences

For the perpetual usage of the KeStudio DriveManager (not including KeStudio), one of the two software licences is required:

Name	Description
KeStudio Drive Engineering, annual	Single user licence for PC, period of use limited to one year

9 Sector-specific components

9.1 Overview

Device	KeDrive D3-IM 300 for the CNC laser machining	KeDrive D3-SMM safe encoder box for robotics
Fig.	 <p>The image shows the KeDrive D3-IM 300 expansion module, a vertical grey unit with the KEBA logo at the top. It features a variety of ports on its front panel, including a USB port, several RJ45 ports, a D-sub connector, and two DVI ports at the bottom. The unit is mounted on a base with two feet.</p>	 <p>The image shows the KeDrive D3-SMM safe encoder box, a vertical grey unit with a front panel featuring six circular ports labeled ENCA1 through ENCA6, and a larger circular port at the bottom. It has a compact, industrial design with mounting tabs on the sides.</p>

KeDrive D3-IM 300 brief description

The KeDrive D3-IM 300 expansion module expands the I/O peripherals of the controller D3-DU 360 for the operation of lasers and the related distance sensors. The high-speed communication interface between controller and module permits extremely short signal delay times and switching pulses, and therefore permits a precise machining process.

- LPC – Laser Power Control: Laser power control via analogue output (0..10 V, 12 bits), can be interpolated over position and path velocity
- POD – Pulse On Demand: Integrated laser pulse generator (PWM) accurately synchronised to the position with a resolution of 10 ns. Pulse width and pulse frequency can be configured in parameters
- FlyCut function: Accurate switching of the laser for a "flying cut" reduces the processing time
- Cut quality independent of the path velocity
- NDC – Nozzle Distance Control: Measurement of the laser head distance signal via analogue input in the CNC cycle. The distance control for the Z axis takes place directly in the CNC controller

D3-SMM brief description

Using the certified encoder box, encoder signals as well as safe inputs and outputs are read decentrally and transferred to the controller via one cable. It is possible to connect to the inputs safe buttons, switches or other controls directly at the machine or close to the robot. All outputs can be used for the safe operation of the motor brake or are available for use as required.

For the safe release of the brakes (also without control cabinet), safety functions are implemented directly in the encoder box - for example to prepare robots for transport. The encoder box is connected via the EtherCAT system bus. The safe exchange of actual values and control commands is possible due to the safety profile FSoE.

9.2 KeDrive D3-IM 300 for laser machining

9.2.1 Overview of the connections

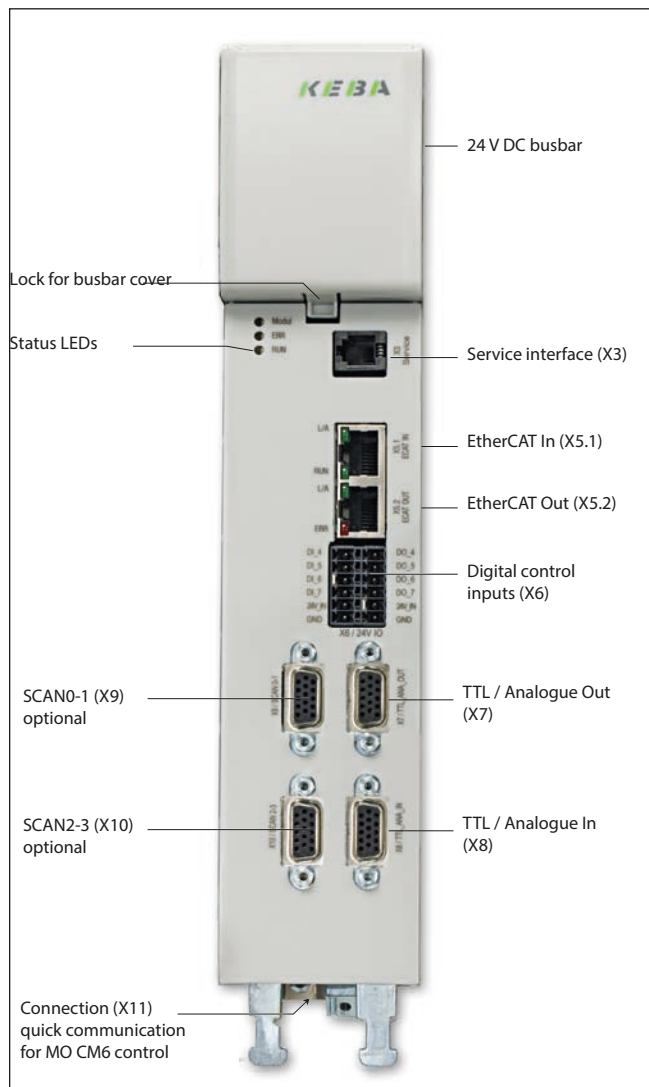

Intended use:

Can only be used in conjunction with:

- KeDrive D3 controller D3-DU 360
- CNC basic firmware for KeDrive D3-DU controller
- KeDrive D3 CNC runtime licence for the laser machining



NOTE:

You will find descriptions and specifications for the module in the Operation Manual

KeDrive D3-IM 300 (ID no.: 1404.214B.x-xx).

Included in the scope of supply

Expansion module	KeDrive D3-IM 300.0x1x.00x0.0
Busbar elements	For 24 V DC supply (pre-assembled)
Documentation	Document set (see Chapter 7.2)

Not included in the scope of supply

Connector set	For control connections X6 (digital inputs)
---------------	---

Article no.

1480.601.0

9.2.2 Order code

Name	D3-	IM	3	0	0	/	A	-	1	1	0	0	-	0	0	0	1	-	0	0	0	0	
Module type	CNC laser module																						
Product line																							
Reserved	0: -																						
Reserved	0: -																						
Cooling	A: Heat sink B: Cooling plate																						
Function	11: I/O module for laser machining 13: I/O module for laser machining + interface for galvanometric scanning heads																						
Reserved	0:																						
Reserved	0: -																						
Options	0: Not including protective coating 1: Including protective coating																						
Version	0:																						
Model	00: Not including product documentation ***) 01: Including product documentation (standard variant)																						
Field bus	0: EtherCAT																						
Reserved																							

***) Only contract customers

9.2.3 Installation and dimensions, KeDrive D3-IM 300 expansion module

The installation sketch and dimensions of the KeDrive D3-IM 300 expansion module are identical to the dimensions of the axis controller BG1, Chapter 7.2.

9.2.4 Connection example:

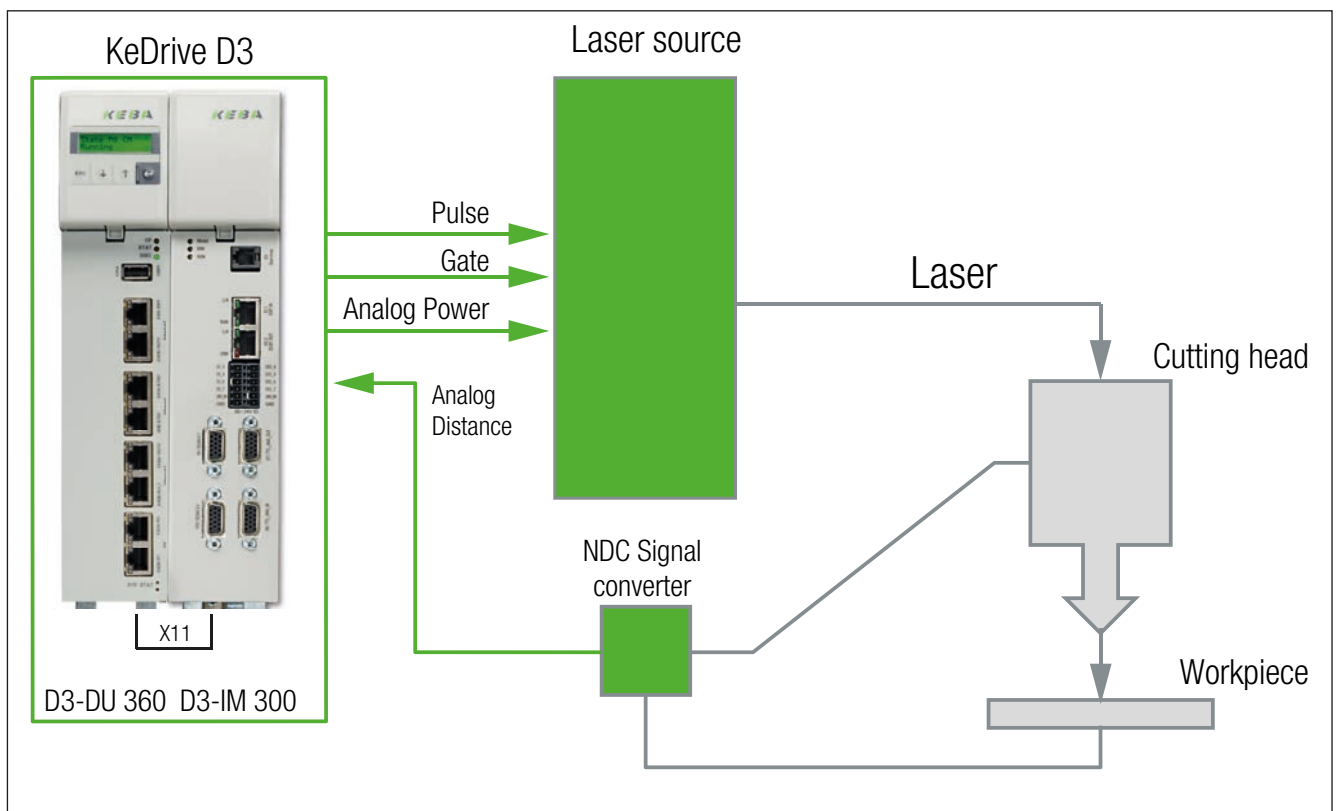

9.3 KeDrive D3-SMM safe encoder box

9.3.1 Overview of the connections

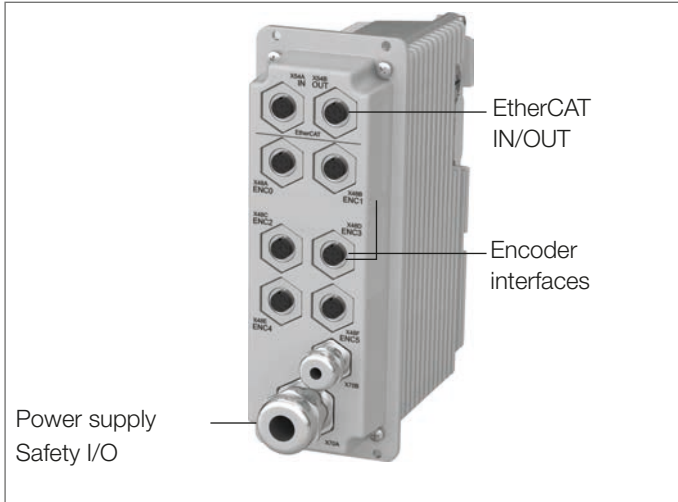

Product characteristics

- Decentral encoder evaluation
- Reduction of the wiring
- Flexible application area
- Fast dynamic monitoring

9.3.2 Order code:

Name	D3-	SMM	3	6	1	/	C	-	0	2	5	0	-	0	0
Name	Safe encoder box														
Product line															
Number of encoder connections	0: - 6: 6 encoder interfaces														
Encoder type	1: Hiperface DSL 2: EnDat 2.2														
Degree of protection	A: - C: IP54														
Reserved	0: -														
Encoder type (slave)	0: - 2: EtherCAT														
Specification I/O	0: 5: 8 SDIs, 10 SDOs, 2 test outputs														
Reserved	0:														
Functional version	0:														
Safety version	0:														

9.3.3 Technical data

Internal safety functions	
SBC Safe Brake Control	Safe operation and monitoring of an external brake
SLS Safely-Limited Speed	Monitoring a speed limit
Digital safety-related inputs	
Number	8
OSSD support	Yes
Number of test outputs for cross-circuit detection	2
Digital safety-related outputs	
Number	10
Rated voltage	24 V DC
Rated current, digital outputs	1 x 2 A; 5 x 1 A; 4 x 0.5 A
Overload protection / short-circuit proof	Yes
Interfaces	
EtherCAT	2 connections
Protocols	CoE, FSoE
Encoder interfaces	6 x Hiperface DSL or 6 x EnDat 2.2
Dimensions, weight	
Dimensions HxWxD	160 x 62 x 131 mm
Weight	1,950 g
Ambient conditions	
Operating temperature	+5 °C to +55 °C
Storage temperature	-40 °C to +70 °C
Relative atmospheric humidity	10% to 95%(without condensation)
Vibration resistance / shock resistance	As per EN 61131-2
General	
Supply voltage	24 V DC, 19.2 V to 30 V, as per EN 61131-2
Current consumption incl. encoder not including I/O	Typ. 600 mA
Max. input current	6.5 A
Max. total power consumption	10 W
Additional power consumption Safety technology I/Os	Lower limit: 144 W
Degree of protection	IP54
Certification	CE, ATEX, TÜV, UL
Cycle time	125 µs / 4 ms (safety functions)
Safety class for I/O	Up to PLe category 4 according to EN ISO 13849-1 Up to SIL3 according to EN 61508

<p>Safety class for SBC</p>	<p>PLd category 3 according to EN ISO 13849-1 per brake output SIL2 according to EN 61508 if used per brake output PLe category 4 according to EN ISO 13849-1 if 2 brake outputs are used SIL 3 according to EN 61508 is 2 brake outputs used</p>
<p>Safety class for SLS</p>	<p>PLd category 3 according to EN ISO 13849-1 if Hiperface DSL encoders are used SIL2 according to EN 61508 if Hiperface DSL encoders used PLe category 4 according to EN ISO 13849-1 if EnDat 2.2 encoders are used SIL 3 according to EN 61508 if EnDat 2.2 encoders used</p>

Example wiring for robotics

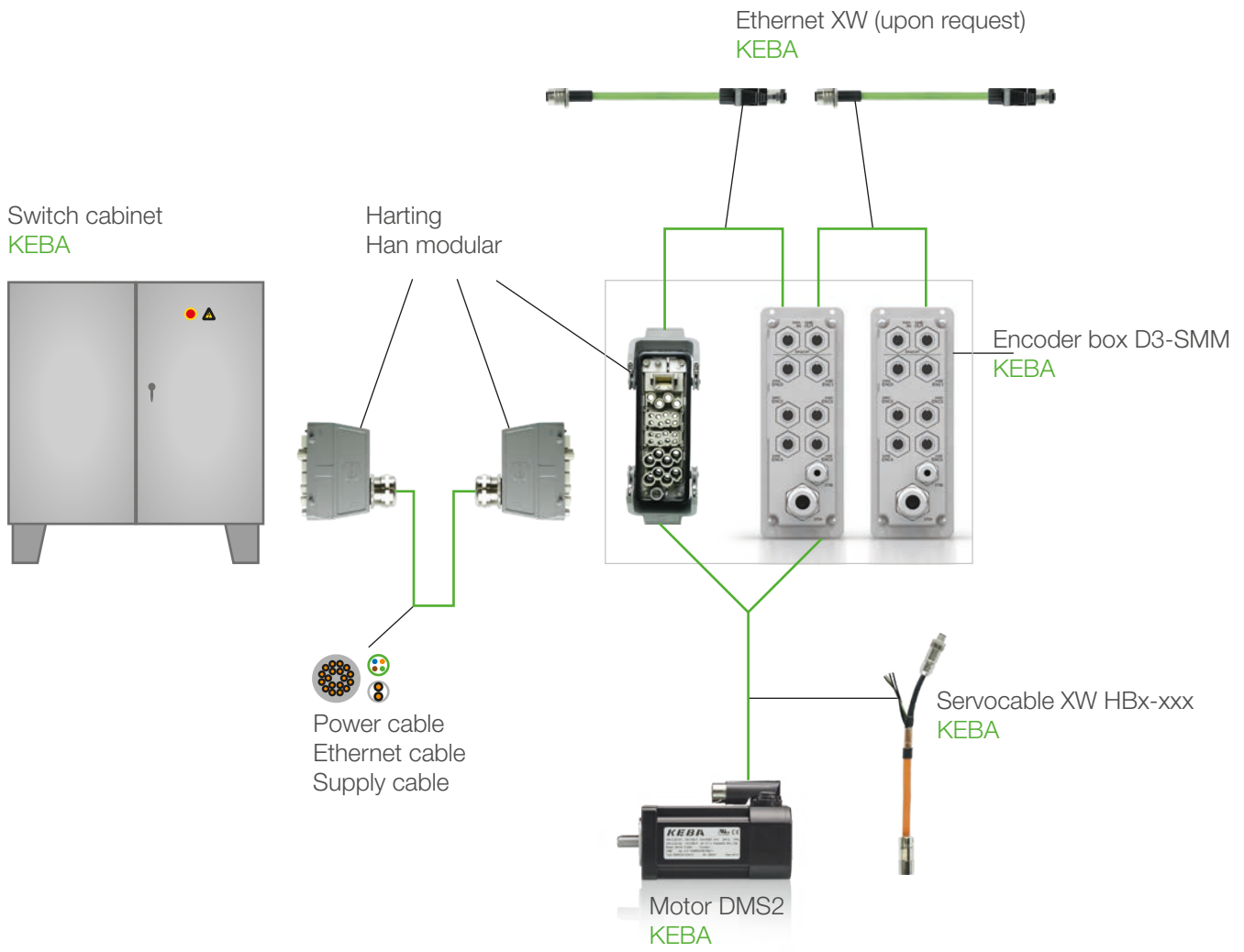

9.3.4 Accessories for KeDrive D3-SMM encoder box

Cable for the communication between encoder box and control unit D3-DU

Suitable for D3-SMM 3xx/x	EtherCAT cable XW xxx-xxx M12 -> RJ45 (upon request)	Figure
Type	Network connection cable	
Specification	Cat 5, Cat 5e	
Shielding	SF/UTP	
Connection type	M12, RJ45	
Connector design	Straight	
Cable length	0.5 m	

Suitable for D3-SMM 3xx/x	EtherCAT cable XW xxx-xxx M12 -> M12 (upon request)	Figure
Type	Cable for connecting two encoder boxes	
Specification	Cat 5, Cat 5e	
Shielding	SF/UTP	
Connection type	M12, M12	
Connector design	Straight	
Cable length	0.5 m	

Further accessories

Suitable for D3-SMM 3xx/x	DIN rail holder D3-XT 250/A	Figure
Type	DIN rail mounting set	
Material	Metal	
Usage	Option for mounting the encoder box on a DIN rail	

Suitable for D3-SMM 3xx/x	Connector set D3-XT 251/A	Figure
Type	M12 connector	
Number	3	
Protection class	IP67	
Usage	Optional 3 x M12 round connectors for the connection of the encoders to the encoder box.	

Suitable for D3-SMM 3xx/x	Blanking plug set D3-XT 252/A	Figure
Type	Blanking plug M12	
Protection class	IP67	
Usage	Optional 20 x M12 blanking plugs for sealing the encoder connectors on the encoder box.	

10 Machine safety components

10.1 System overview

D3-DA 3xx - SDC (example BG1) with expanded functional safety FSM modules SafetyManager (not for robotics)



FSM-1



FSM-2

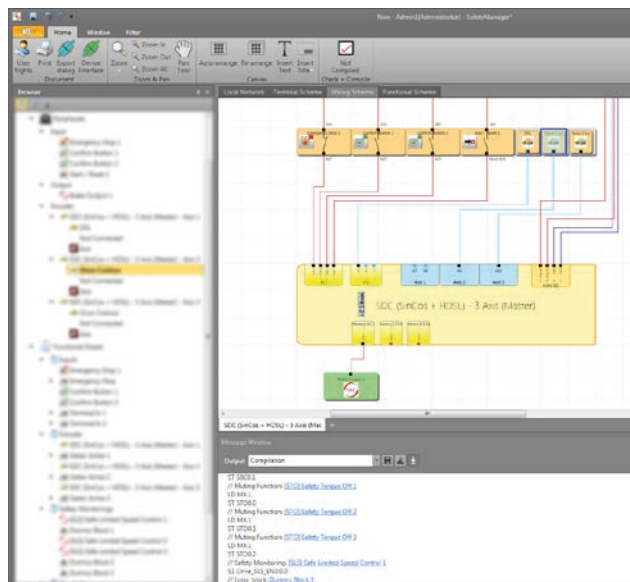

SafetyManager

With the model SDC (available for BG1 to BG4) safe and non-safe encoders and encoder combinations on the axis controller can be evaluated and motion sequences safely monitored.

KEBA makes it possible to program safe machine logic straightforwardly via the safe field bus system FSoE using the FSM assemblies.

With the aid of SafetyManager, complex safety solutions can be straightforwardly programmed graphically such that a good overview of the complete safety solution is always available.

See Model Description
SDC Axis Controller
(ID no.: 1404.206B.x)

See Installation Manual
FSM Assemblies
(ID no.: 1781.20B.x)

See Programming Manual
SafetyManager (ID no.: 1102.22B.x)



NOTE:

The latest operation manuals and other documents are available in German, English and other languages and can be downloaded from our homepage

<https://www.keba.com/de/industrial-automation/service-support/downloads/doku-data-portal>

10.2 KeDrive D3-DA SDC (FSoE slave)

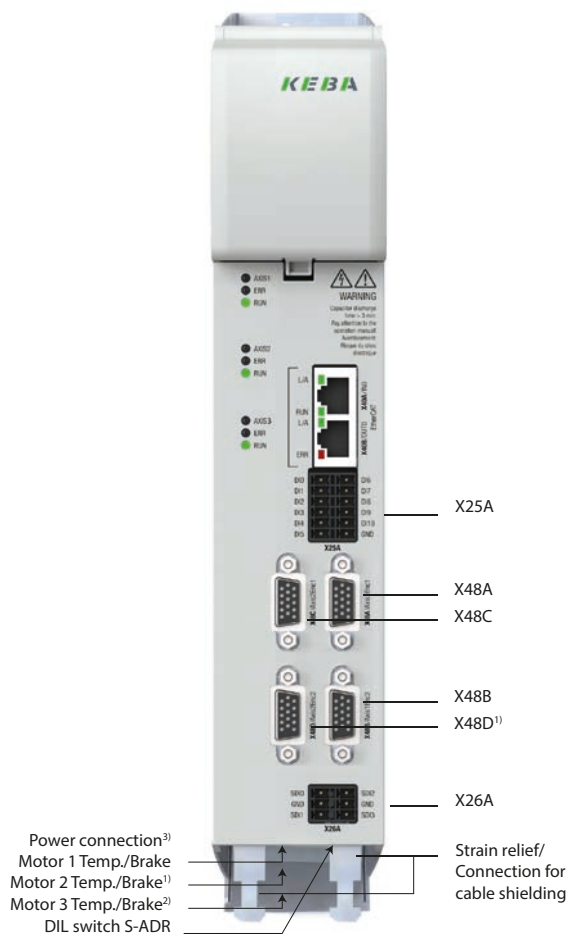

- X48A, X48B, X48C, X48D encoder interfaces with safe encoder evaluation
- X25A control connections
- X26A safe inputs
- X31A, X31B, X31C motor power connections with safe brake output
- S-ADR DIL switch block for setting the FSoE address

1) Only on KeDrive D3 double and triple-axis controllers.
 2) Only on KeDrive D3 triple-axis controllers.
 3) Arranged on underside of the D3-DA 3xx axis controller

Safety-related characteristic data, KeDrive D3-DA SDC

Performance Level according to EN 13849	PL e
Architecture	Cat.4
Safety Integrity Level according to EN 61508	SIL 3
PFH	2.57 E-08
Proof test interval	20 years = max. switch-on duration

General

Number of safe inputs	4
Number of safe brake outputs	1 per axis
Safe field bus functionality	FSoE / PROFIsafe slave
Safe encoder evaluation	HIPERFACE DSL Sin/Cos, resolver, HTL

Electrical data

	24 V DC, 15 mA, OSSD support
Rated data, safe digital inputs	Type 1 in accordance with EN 61131-2
Rated data, safe brake output	24 V DC, 2 A

10.3 FSM-1 module (FSoE master)

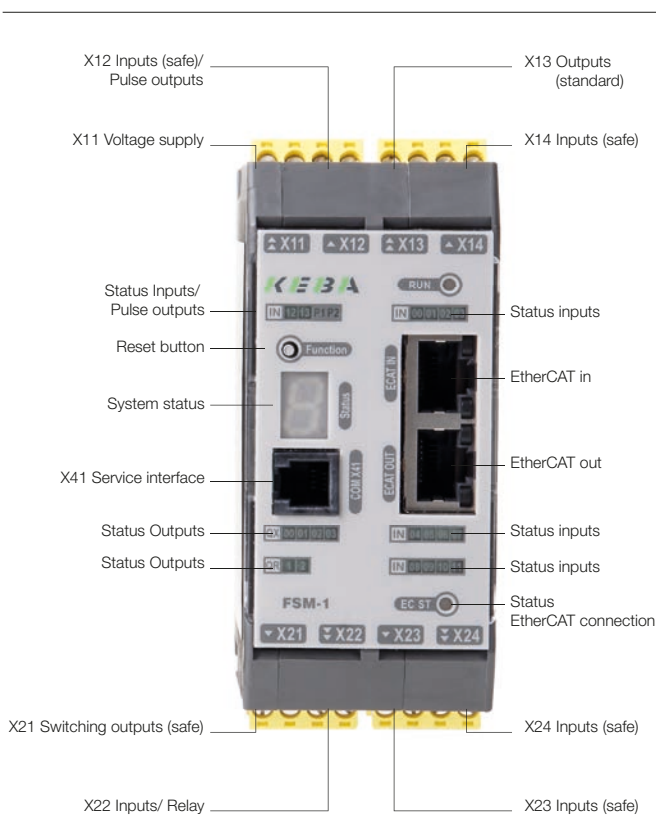

Description

Freely programmable and configurable FSoE master module for use in EtherCAT® networks. Features include:

- Can be programmed conveniently and clearly using SafetyManager
- Library for all common IO elements (emergency stop, door interlock, light curtain, etc.)
- Straightforward integration of safe drives

Included in the scope of supply		Article no.
FSM-1 module	Is delivered with the connectors for the inputs and outputs, as well as for the supply of power (in the inserted state).	1781.0001
Document set	Contains a booklet with warnings and safety instructions as well as data carrier with installation manual, programming manual etc.	1020.850.0-x

Accessories (not included in the scope of supply)		Article no.
SafetyManager	The graphic PC software is required to create the machine safety application.	Downloads
Dongle	The USB dongle is necessary to authenticate the programmer as well as to prepare and change safety programs.	1102.0100
Data cables	Ethernet connection cable type CC-ECL03	1109.0002
Programming adapter SMC-C20	(USB-RS485 / X41) for programming/service, if communication via EtherCAT is not possible.	1181.0008

10.3.1 Technical data, FSM-1

Safety-related characteristic data	
Performance Level according to EN 13849	PLe
Architecture	Cat.4
Safety Integrity Level according to EN 61508	SIL 3
Proof test interval	20 years = max. switch-on duration
PFH	7.86 E-09
General	
Number of safe inputs	14 (support OSSD)
Number of safe outputs	2* (pn-switching)
	4* (pp-switching)
Number of relay outputs	2
Number of standard outputs	2
Number of pulse outputs	2
Type of connection	Plug-in terminals with screw connection
Max. number of FSoE slave modules	12
Electrical data	
Supply voltage	24 V DC (-10%/ +15%)
Rated data, digital inputs	24 V DC; 20 mA, type 1 according to EN 61131-2
Rated data, digital outputs	24 V DC; 2 A
Rated data, relay	24 V DC; 2 A / 230 V AC; 2 A
Rated data, signal outputs	24 V DC; 0.5 A
Pulse outputs	24 V DC; 0.5 A
Fuse protection for supply voltage	2 A (module)
	10 A (outputs)
Ambient conditions	
Temperature	50 °C
Protection class	IP 20
Climate class	3K3, EN 60721-3
EMC	EN 61000-6-4, EN 61000-6-2 EN 61000-6-7, EN 61800-3 EN 62061, EN 61326-3
Size (HxDxW)	100 x 115 x 45 mm
Weight	312 g
Fastening	Snap-action on DIN rail
Max. connection cross-section	2.5 mm ²

* Can be configured using SafetyManager.

10.4 FSM-2 module (FSoE master)

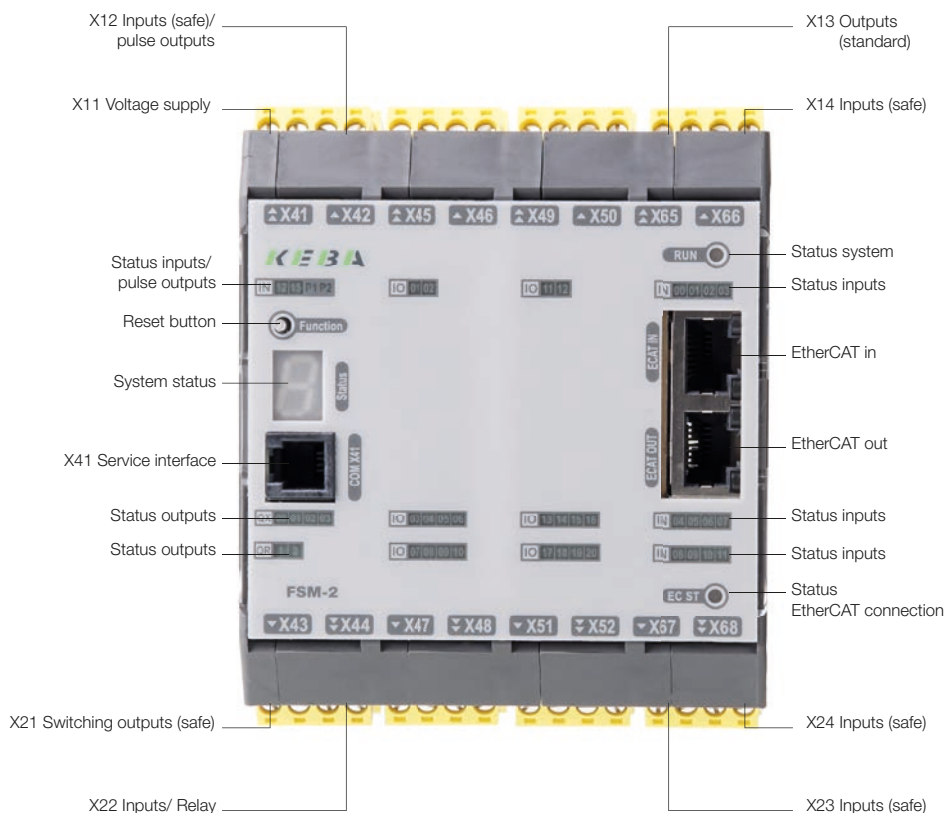

Description

Freely programmable and configurable FSoE master module for use in EtherCAT® networks. Features include:

- Can be programmed conveniently and clearly using SafetyManager
- Library for all common IO elements (emergency stop, door interlock, light curtain, etc.)
- Straightforward integration of safe drives

Included in the scope of supply		Article no.
FSM-2 module	Is delivered with the connectors for the inputs and outputs, as well as for the supply of power (in the inserted state).	1781.0001
Document set	Contains a booklet with warnings and safety instructions as well as data carrier with installation manual, programming manual etc.	1020.850.0-x

Accessories (not included in the scope of supply)		Article no.
SafetyManager	The graphic PC software is required to create the machine safety application.	Downloads
Dongle	The USB dongle is necessary to authenticate the programmer as well as to prepare and change safety programs.	1102.0100
Data cables	Ethernet connection cable type CC-ECL03	1109.0002
Programming adapter SMC-C20	(USB-RS485 / X41) for programming/service, if communication via EtherCAT is not possible.	1181.0008

10.4.1 Technical data, FSM-2

Safety-related characteristic data	
Performance Level according to EN 13849	PLe
Architecture	Cat.4
Safety Integrity Level according to EN 61508	SIL 3
Proof test interval	20 years = max. switch-on duration
PFH	7.96 E-09
General	
Number of safe inputs	14 (support OSSD)
Number of safe outputs	2* (pn-switching)
	4* (pp-switching)
Number of relay outputs	2
Number of standard outputs	2
Number of pulse outputs (clocked)	2
Number of safe digital I/Os	20
Type of connection	Plug-in terminals with spring or screw connection
Max. number of FSoE slave modules	32
Electrical data	
Supply voltage	24 V DC (-10%/ +15%)
Rated data, digital inputs	24 V DC; 20 mA, type 1 according to EN 61131-2
Rated data, digital outputs	24 V DC; 2 A
Rated data, relay	24 V DC; 2 A / 230 V AC; 2 A
Rated data, signal outputs	24 V DC; 0.5 A
Pulse outputs	24 V DC; 0.5 A
Fuse protection for supply voltage	3.15 A (module)
	10 A (outputs)
Ambient conditions	
Temperature	50 °C
Protection class	IP 20
Climate class	3K3, EN 60721-3
EMC	EN 61000-6-4, EN 61000-6-2 EN 61000-6-7, EN 61800-3 EN 62061, EN 61326-3
Size (HxDxW)	100 x 115 x 90 mm
Weight	312 g
Fastening	Snap-action on DIN rail
Max. connection cross-section	2.5 mm ²
* Can be configured using SafetyManager.	

10.5 SafetyManager

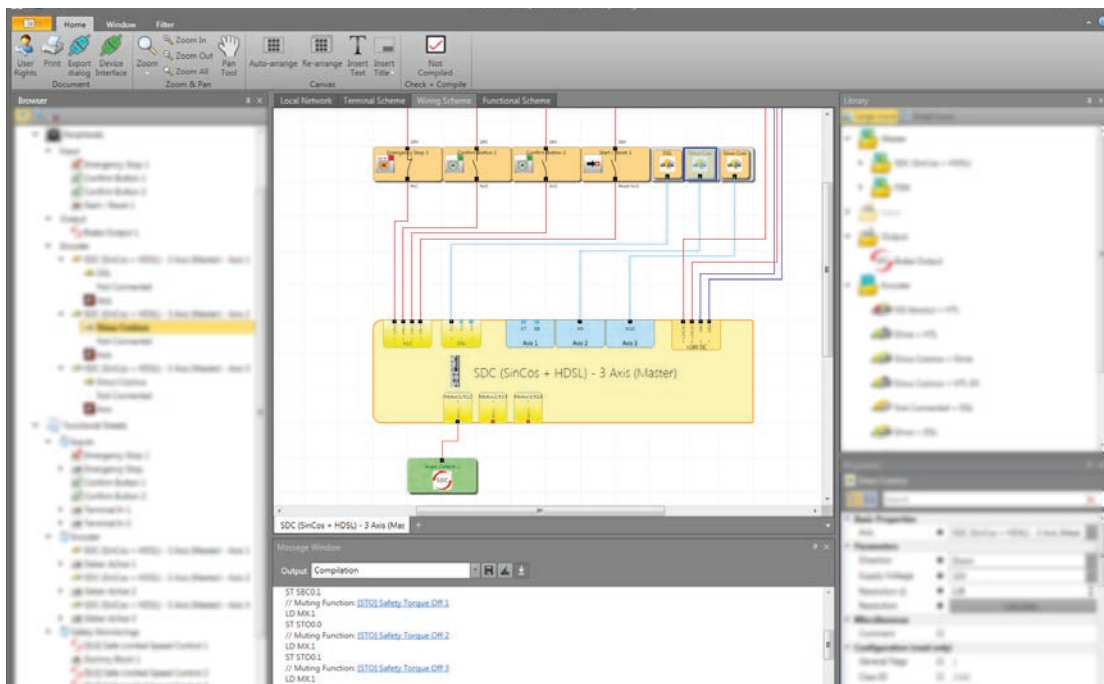

Description

The program "SafetyManager" is a graphics-oriented software application for preparing a PLC-based monitoring program for a safety system based on the SDC option, FSM assemblies as well as additional IO peripherals.

This programming software permits the graphic preparation of sequentially executed programs using function blocks; it also makes it possible to configure speed and position-based safety functions and their related components (device and encoder settings, axes, measuring paths and the connection of safety functions in the logic). The tool also provides diagnostic functions.

System requirements

To install the program, the following system requirements must be met:

Minimum requirements

OS:	Windows 8, Windows 10 (32 bits/64 bits)
Processor:	Intel® Pentium® 4 or AMD Athlon™ Dual Core; 3.0 GHz or better
Memory:	At least 2 GB
HDD:	At least 500 MB spare hard disk space

Recommended system requirements

Processor:	Intel® Core™ i3 or AMD Quad Core; 3.0 GHz or better
Memory:	4 GB or more



NOTE:

SafetyManager is not optimised for usage on mobile touch devices such as tablets or smartphones. SafetyManager cannot be used for robotics.

11 Servomotors

11.1 Overview

Motor type	Features
 <p data-bbox="193 949 595 976">LSP servomotor design with planetary gearbox</p>	<p data-bbox="681 465 1318 528">LSP servomotor with optional planetary gearbox – slim and cost-effective</p> <p data-bbox="681 551 1433 645">The LSP product range meets the highest demands on robustness and reliability and is available in different flange sizes and varying lengths with various torque graduations.</p> <p data-bbox="681 667 1436 730">The motor product range offers a homogeneous, graduated mass inertia progression over the entire product range.</p> <p data-bbox="681 752 1439 846">The further enhancement of the classic winding technology in the motors makes it possible to produce compact designs and reduces production costs.</p> <ul data-bbox="681 900 1474 1182" style="list-style-type: none"> • Stall torque from 0.18 to 110 Nm • 7 flange sizes (40, 60, 80, 100, 130, 150, 190), degree of protection up to IP 65 • Highest demands on synchronism and accuracy due to greater moment of inertia • Directly attached planetary gearbox without intermediate flange • One-cable solution available for power and encoder signal • CE, UKCA and UL acceptance
 <p data-bbox="277 1585 507 1612">KeDrive-DMS2 servomotor</p>	<p data-bbox="681 1200 1024 1227">KeDrive-DMS2 servomotor</p> <p data-bbox="681 1249 1452 1344">The KEBA servomotors in the product range DMS2 meet the highest requirements on accuracy and smooth running and are characterised by a broad power spectrum and a broad speed range.</p> <p data-bbox="681 1366 1465 1429">Depending on the application, the motors can be customised to the related conditions by means of numerous options.</p> <ul data-bbox="681 1451 1458 1742" style="list-style-type: none"> • Stall torque from 0.24 to 300 Nm • 8 flange sizes (40, 58, 70, 91, 100, 142, 190, 240, 270) • High dynamic performance and efficiency due to low moment of inertia • Numerous customisation options and other options • One-cable solution available for power and encoder signal • CE, UKCA and UL acceptance • Air and water cooling possible • Electronic rating plate available

Motor type	Features
 <p data-bbox="325 757 461 784">LSN servomotor</p>	<p data-bbox="681 385 1225 416">LSN servomotor – compact and adaptable</p> <p data-bbox="681 436 1474 557">The manufacturing process for the LSN motor product range permits a large number of variants also / even for small quantities. The product range offers a variety of possibilities for the mechanical adaptation of shaft and housing to customer requirements.</p> <p data-bbox="681 586 1461 676">The winding is designed as a concentrated 10-pole winding and as a result permits a very high power density and dynamic performance in the "high-end sector".</p> <ul data-bbox="681 698 1385 952" style="list-style-type: none"> • Stall torque from 0.28 to 60 Nm (externally cooled up to 78 Nm) • 6 flange sizes (50, 74, 97, 127, 158, 190) • Very high power density and high dynamic performance • Degree of protection IP54 to IP64 (optionally IP65) available • Air and water cooling possible • CE with ATEX (zone 2 / 22), UKCA and UL acceptance • Large selection of encoders available

 <p data-bbox="325 1361 461 1388">LST servomotor</p>	<p data-bbox="681 976 1120 1008">LST servomotor - the versatile one</p> <p data-bbox="681 1025 1461 1146">The manufacturing process for the LSN motor product range also permits numerous variants also / even for small quantities. The product range offers a variety of possibilities for the mechanical adaptation of shaft and housing to customer requirements.</p> <p data-bbox="681 1176 1442 1236">Featuring classic winding technology, the LST motor combines all the advantages of a fast 6-pole synchronous servomotor.</p> <ul data-bbox="681 1258 1474 1541" style="list-style-type: none"> • Stall torques from 0.1 to 115 Nm • 8 flange sizes (37, 50, 74, 97, 127, 158, 190, 220) • Well suited to speeds up to 9000 min⁻¹ • High overload capacity even at standstill due to efficient heat distribution in the stator core • Air and water cooling possible • Possible to increase the moment of inertia at the shaft • CE, UKCA and UL acceptance
---	---

**NOTE:**

You will find further details about the various servomotor series in the related order catalogue.

11.1.1 Servomotors order catalogues



Servomotor Series LSP Order Catalogue (ID no.: 0814.28B.x)



Servomotors Series DMS2 Order Catalogue



Servomotor Series LSN/LST Order Catalogue (ID no.: 0814.25B.x)

Downloads

You will find the latest information about our products on our website:

www.keba.com in [Documentation and Downloads](#)

11.2 System cables

Ready-made power, encoder and hybrid cables are available for all motors for operation on the related KEBA drive controller.

Ready-made KEBA cables are matched to the requirements of the system components and checked in relation to conformity and function with the related max. permissible lengths.

EMC immunity is maintained by means of matched KEBA components for the motor, cables and mains filter.

All connection cables are suitable for use in drag chains, have a colour scheme as per Desina® and can be supplied on the motor side up to degree of protection IP67.



System Cables Order Catalogue (ID no: 0966.24B.x)

Downloads

You will find the order catalogues and the latest information about our products on our website:

www.keba.com in [Documentation and Downloads](#)



For information about system cables for DMS2 motors, see project manual

KEBA Industrial Automation Germany GmbH

Gewerbestr. 5-9, 35633 Lahnu/Germany, Phone +49 6441 966-0, info@keba.de

KEBA Industrial Automation GmbH

Reindlstr. 51, 4040 Linz/Austria, Phone +43 732 7090-0, keba@keba.com

KEBA Group worldwide

Austria / China / Czech Republic / Germany / India / Italy / Japan / Netherlands /
Romania / South Korea / Switzerland / Taiwan / Turkey / United Kingdom / USA

www.keba.com

Copyright © 2022 KEBA All rights reserved.

All content of the documentation, in particular the text, photographs and graphics it contains are protected by copyright. The copyright lies, unless otherwise expressly stated, with KEBA Industrial Automation Germany GmbH.



KEBA[®]

Automation by innovation.